

MILLENNIUM[®]

FOAM



SURFBOARD BLANK CATALOG 2015

**ORDER ONLINE AT:
WWW.MILLENNIUMFOAM.COM**

310.323.5386
MILLENNIUMFOAM@GMAIL.COM

REVISED 1.1.2015

Over the last few years Millennium Foam has been quietly working at producing high quality polyurethane surfboard blanks. With deep experience in foam and urethane manufacturing, we have developed a product that is strong, light, and bright white. The feedback we receive is that the foam does not “resist” shaping tools. The cell structure is tight, yet not so dense as to be difficult to shape. The strength of the foam carries to the rails. Alleviating a common blank problem of soft foam at the rails.

AVAILABLE DENSITIES

- PINK- Team Light
- RED- Hyperlight
- YELLOW- Ultralight
- BLUE- Base Density/Standard
- BLACK- Classic

MOLECULAR OPTICAL BRIGHTENING (MoB)

The recent trend in blank manufacturing is a move from a standard bright white blank color, to an enhanced color tone. Originally, the optical enhancement was left up to the resin used in glassing. Now blanks also contain brightening agents. The optical brightening helps the finished boards keep their white color longer and works in harmony with optical enhancers in commonly used resins. Our MOLECULAR OPTICAL BRIGHTENING is the result of over a year of testing and product development. Our radiant violet enhancement adds a longer, brighter “shelf life” to finished boards on the retail floor, as well as exceptional brightness in sunlight. The “MoB” is available in all our blanks, and does not effect strength, weight, or shape ability.

BLANK CATALOG/STRINGER OPTIONS

Our blank selection, as represented in our catalog, is well rounded and can accommodate most shapers needs. Particularly for shapers that rely extensively on shaping machines.

We also have a full selection of stringer wood and the skill to build any stringer configuration. We have also instituted a full CNC stringer cutting system. This allows for ultimate precision with rocker masters and the flexibility to take a board file and drop the required deck line on to our blank.

STRINGER WOOD SELECTION

- Solid Bass, custom thickness available
- Solid Clear Red Cedar, custom thickness available
- 3.6mm Poplar Ply
- 4mm Poplar Ply
- 4.5mm Poplar Ply
- 6.5mm Poplar Ply
- APPLECORE 1/8 BASS PLY
 - Various Color Ways Stocked, please call for availability
- High Density Colored Foam

Although a quality blank is paramount, another segment we have been fine tuning is our logistics. To improve in that segment we have increased our stocking of popular blanks. With a new hub in Oceanside California, our service has improved. We deliver to Ventura

County weekly and Northern California monthly. It is our experience that consistent deliveries increase the productivity of our customers.

Finally, we have a full online order system via our web store: millenniumfoam.com. Via the web portal a customer can order blanks, add custom stringers, and request custom rockers. A confirmation will be generated and emailed to the customer. The order then enters the production cycle.

We look forward to having the opportunity to provide you with quality blanks

order@millenniumfoam.com

www.millenniumfoam.com

310.323.5386



MILLENNIUM
FOAM  **BUILD ON QUALITY**

ORDER@MILLENNIUMFOAM.COM
310.323.5386

FOAM DENSITY CHART



MILLENNIUM
FOAM  **BUILD ON QUALITY**

ORDER@MILLENNIUMFOAM.COM
310.323.5386

MILLENNIUM FOAM BLANK MARKINGS

BOTTOM OF BLANK

Blank weight is designated by color on the tip of blank:

- "Black"-Classic
- "Blue"- Standard
- "Yellow"- Ultra Light
- "Red"- Hyperlite
- "Pink"- Team Light

Our blanks contain other number codes as well, and a production date. If any quality issue becomes a pattern, please make note of the date and the production code before shaping.

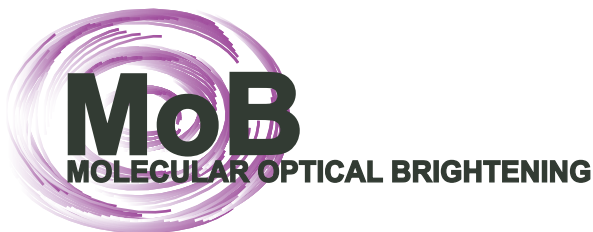
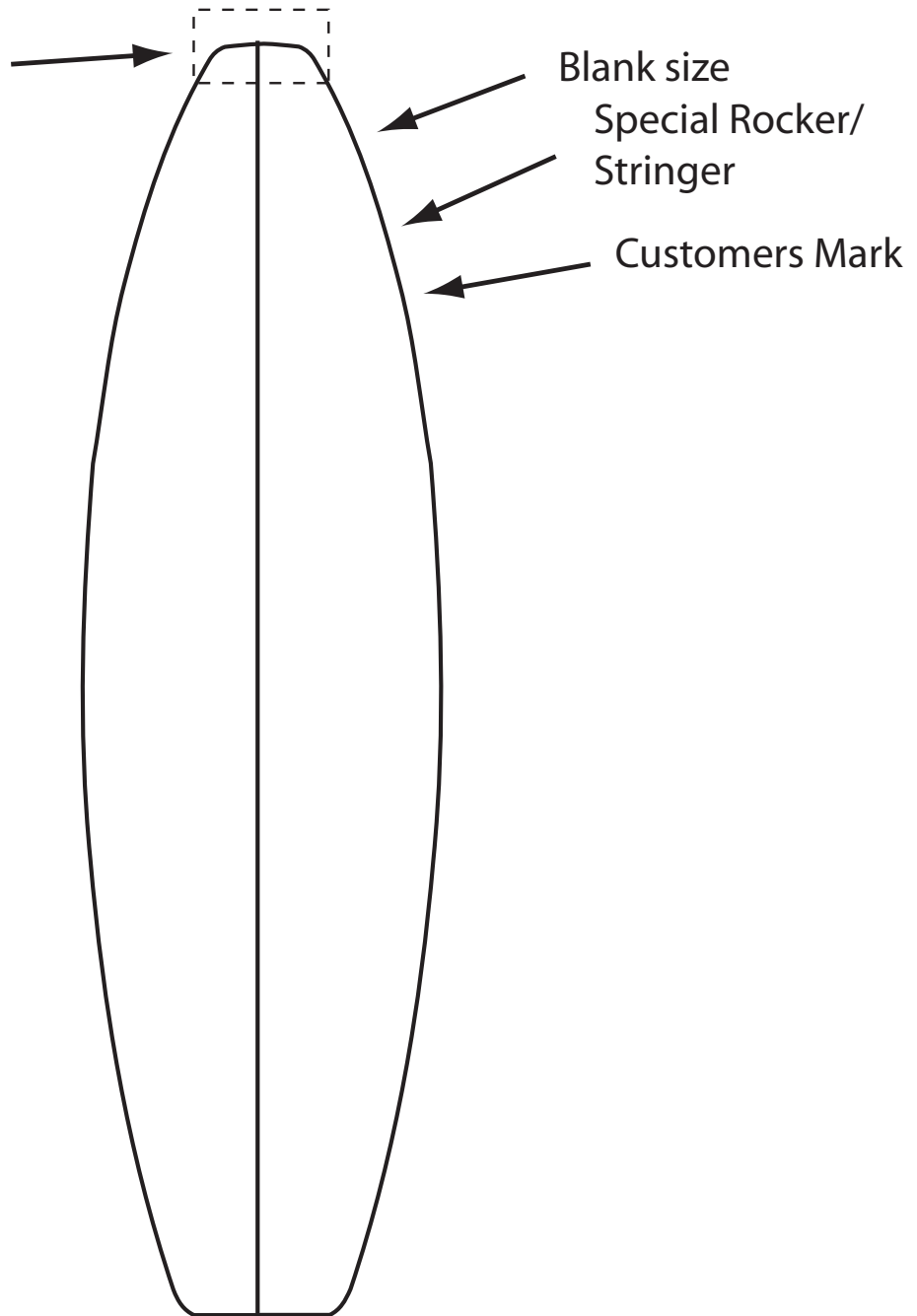

MILLENNIUM
FOAM  **BUILD ON QUALITY**

ORDER@MILLENNIUMFOAM.COM
310.323.5386

5'3"G

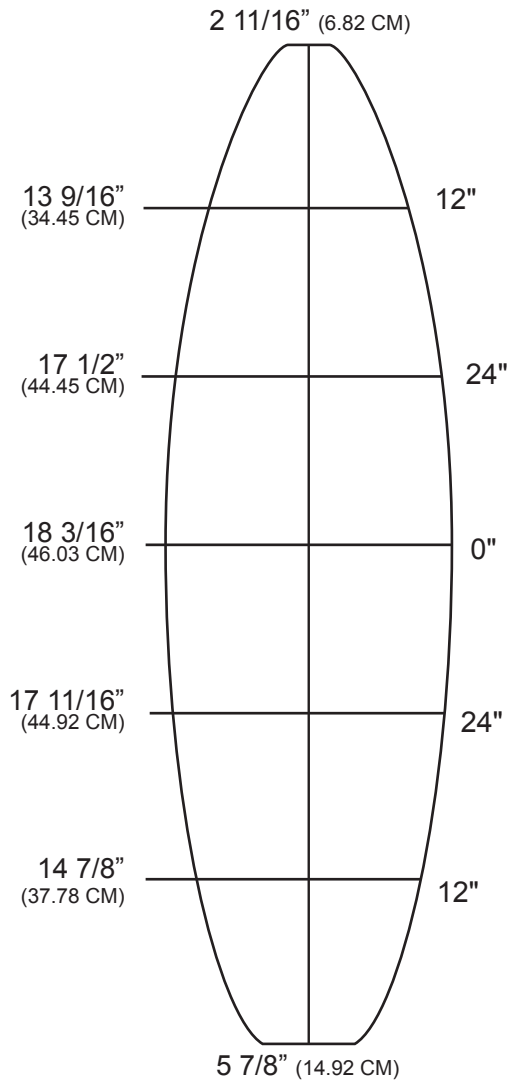

BOTTOM LENGTH: 5' 4 1/4" (163.83 CM)

TIP TO TIP LENGTH: 5' 3 1/2" (161.29 CM)

MAX WIDTH: 18 3/16" (46.03 CM)

THE 53G WAS CLEARLY DESIGNED WITH THE 'GROM' IN MIND. AS KIDS START SURFING YOUNGER BLANKS NEED TO ACCOMIDATE THE VERY SMALL SHORTBOARD. LARGER BLANKS BECOME PROBLAMATIC WITH ROCKER AND FOIL, ALSO WITH OVERSHAPING. FOR THE SUB-5'1" THIS BLANK IS IDEAL. LIKE ALL OUR BLANKS THE VOLUME IS CARRIED TO THE RAIL.

VOLUME: 26.9 L

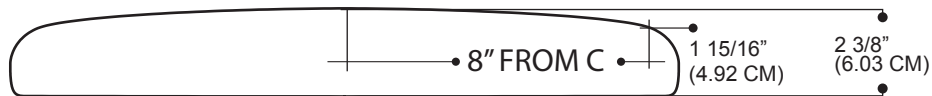
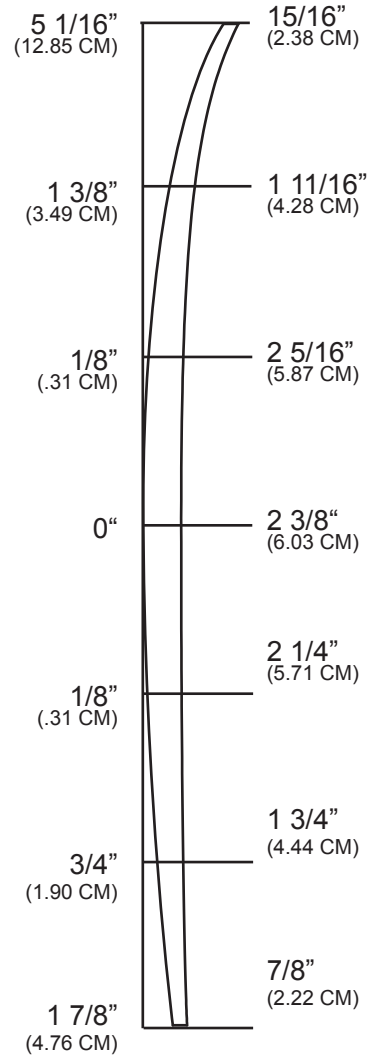

CENTER DECK SCALE CROSSSECTION

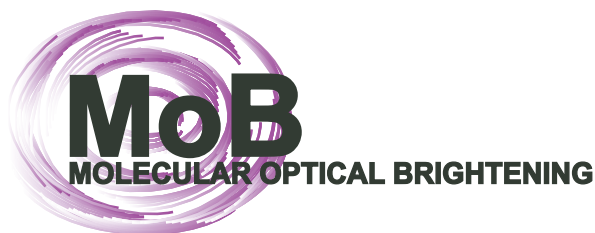

MILLENNIUM
FOAM  BUILD ON QUALITY

ORDER@MILLENNIUMFOAM.COM
310.323.5386

5'8"R

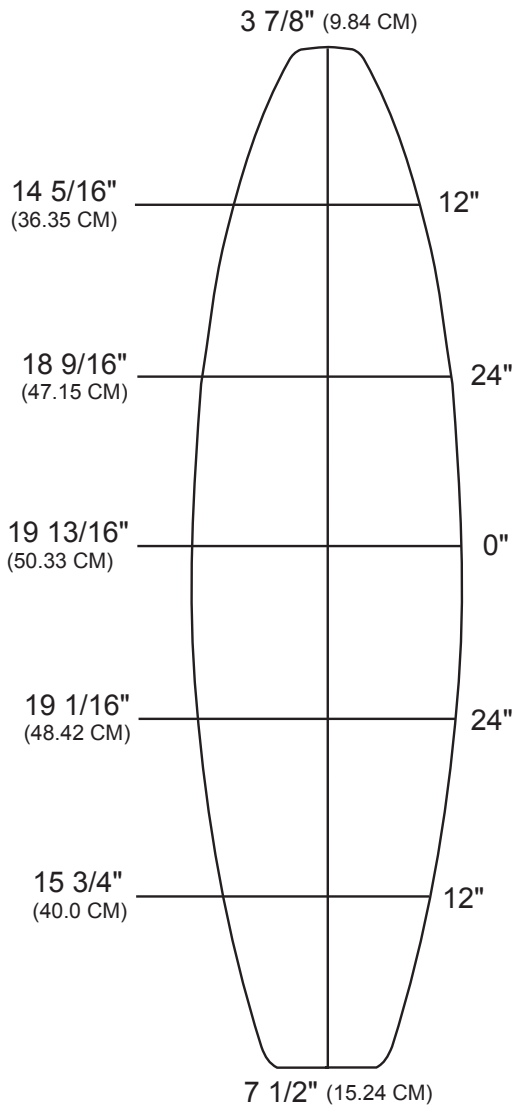

BOTTOM LENGTH: 5' 9 3/4"
(177.16 CM)

TIP TO TIP DECK: 5' 9 1/8"
(175.58 CM)

MAX WIDTH: 19 13/16" (50.33 CM)

MAX THICKNESS: 2 11/16"
(6.82 CM)

A CURRENT VERSION OF THE "GROM" STYLE BLANK. THE TREND OF CARRYING FINISHED THICKNESS TO THE OUTER RAILS IS EASILY ACOMIDATED IN HERE. FOR EXAMPLE: AT EIGHT INCHES OFF CENTER IN THE MIDDLE OF THE BLANK, THE RAIL IS 2" THICK. THAT FULLNESS IS PROPORTIONED FROM NOSE TO TAIL.

VOLUME: 35.5L

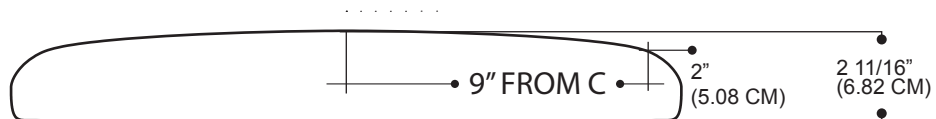
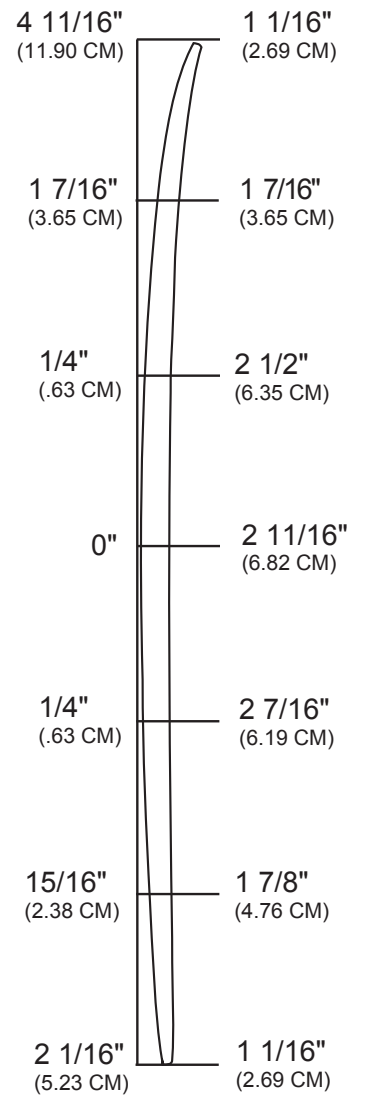

CENTER DECK SCALE CROSSSECTION

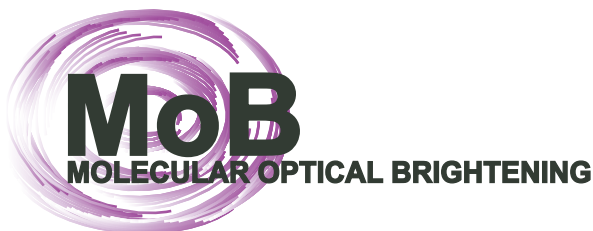

MILLENNIUM
FOAM  BUILD ON QUALITY

ORDER@MILLENNIUMFOAM.COM
310.323.5386

6'0"CB

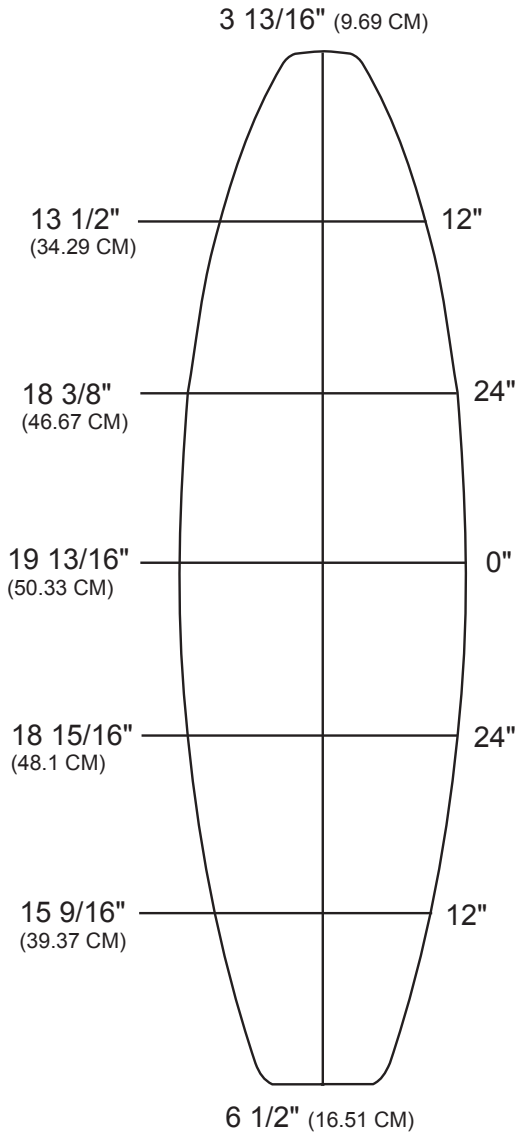

BOTTOM LENGTH: 6' 1" (185.42 CM)
 TIP TO TIP DECK: 6' 0" (182.88 CM)
 MAX WIDTH: 19 13/16" (50.33 CM)
 MAX THICKNESS: 2 5/8" (6.67 CM)

SHAPED BY: CHRIS BORST,
 OCTOBER 2006

COMMENTS:
 THE FIRST IN THE "CB" LINE
 OF SHORTBOARD BLANKS.
 BUILT TO BE A CLOSE
 TOLERANCE MODERN
 SURFBOARD BLANK. BUILT
 FOR THE NEEDS OF SHAPERS
 TO PRODUCE SUB 6' SHAPES.

VOLUME: 34.0L

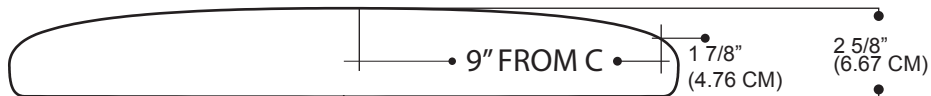
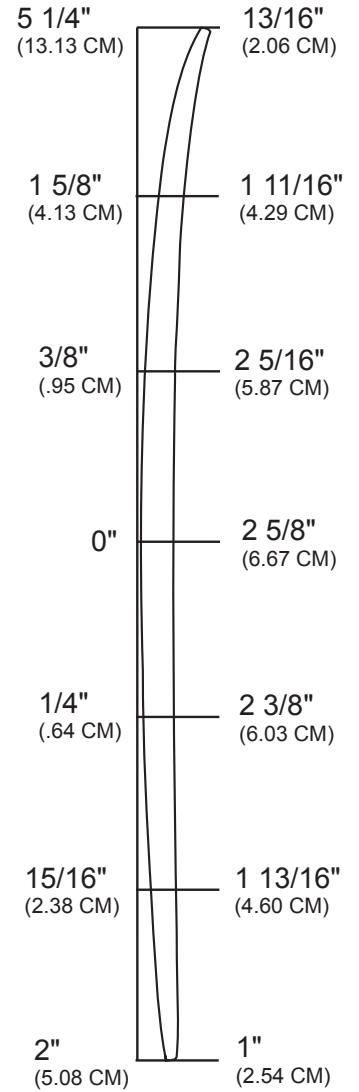

CENTER DECK SCALE CROSSECTION

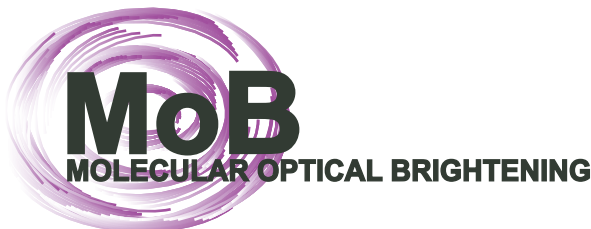

MILLENNIUM
 FOAM BUILD ON QUALITY

ORDER@MILLENNIUMFOAM.COM
 310.323.5386

6'0"DE

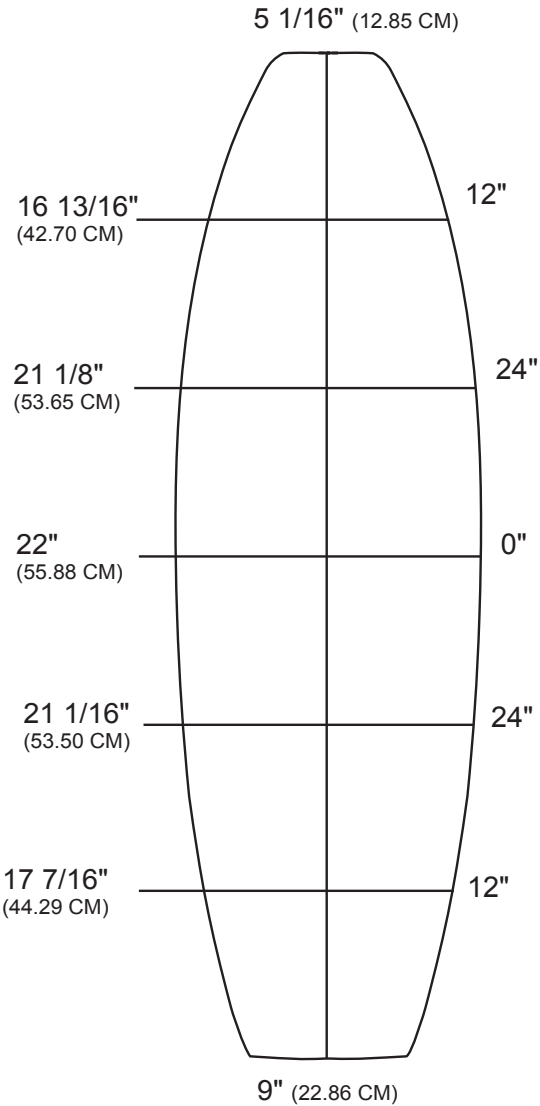

BOTTOM LENGTH: 6' 1/4"
(183.51 CM)

TIP TO TIP DECK: 6' 0" (182.88 CM)

MAX WIDTH: 22" (55.88 CM)

MAX THICKNESS: 3" (7.62 CM)

COMMENTS:
THIS BLANK WAS SPECIFICLY
DESIGNED FOR THE NEW
TREND IS SHORT BOARDS.
WIDER CENTER, WIDER TAILS,
SHORTER, AND MORE VOLUME
OUT TO THE RAILS.

VOLUME: 45.9L

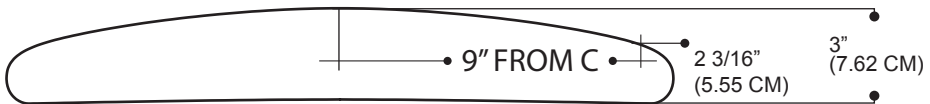
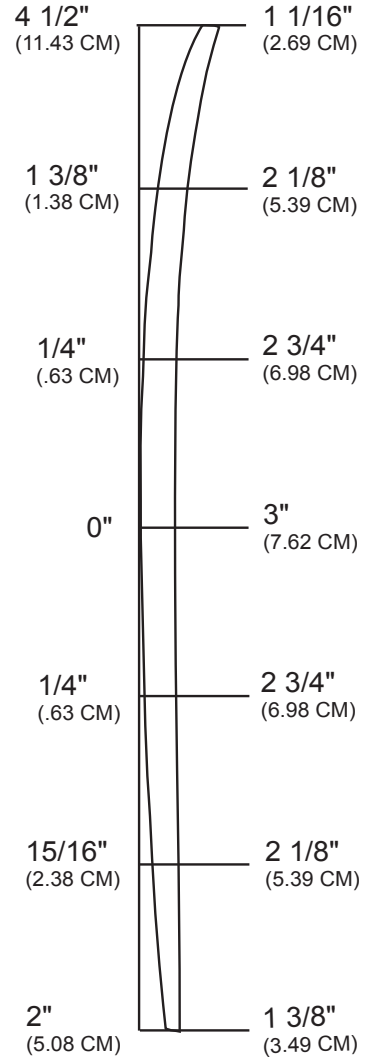

CENTER DECK SCALE CROSSECTION



MILLENNIUM
FOAM BUILD ON QUALITY

ORDER@MILLENNIUMFOAM.COM
310.323.5386

6'1" DG

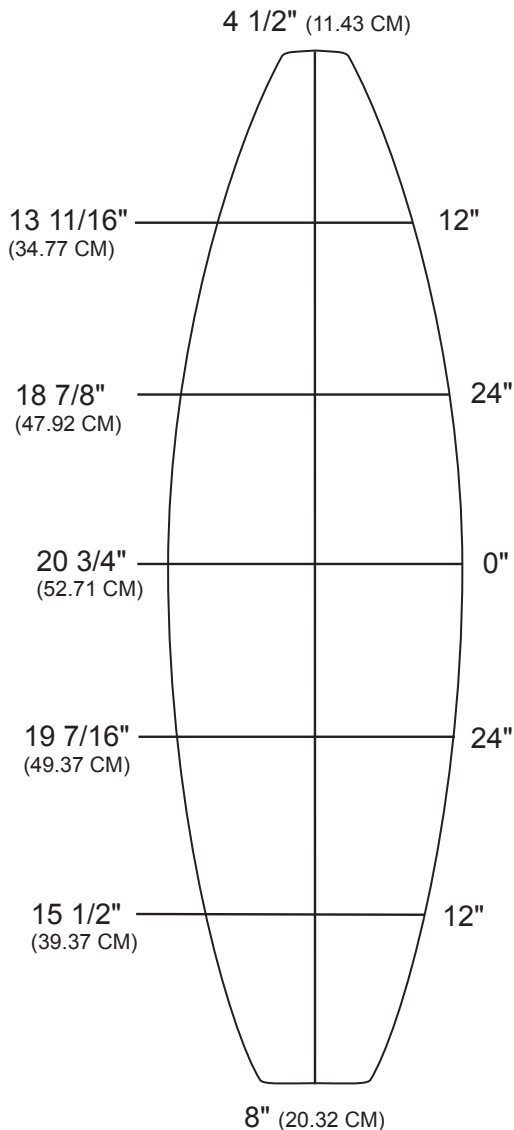

BOTTOM LENGTH: 6' 1 1/2"
(186.7 CM)

TIP TO TIP DECK: 6' 13/16" (184.9 CM)

MAX WIDTH: 20 3/4" (52.71 CM)

MAX THICKNESS: 3" (7.62 CM)

COMMENTS:
BLANK DESIGNED FOR MACHINE CUTTING. CARRIES EXTRA THICKNESS AND A FLATTER DECK

VOLUME: 42.6L

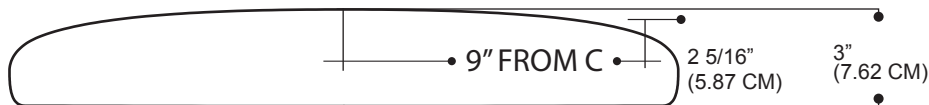
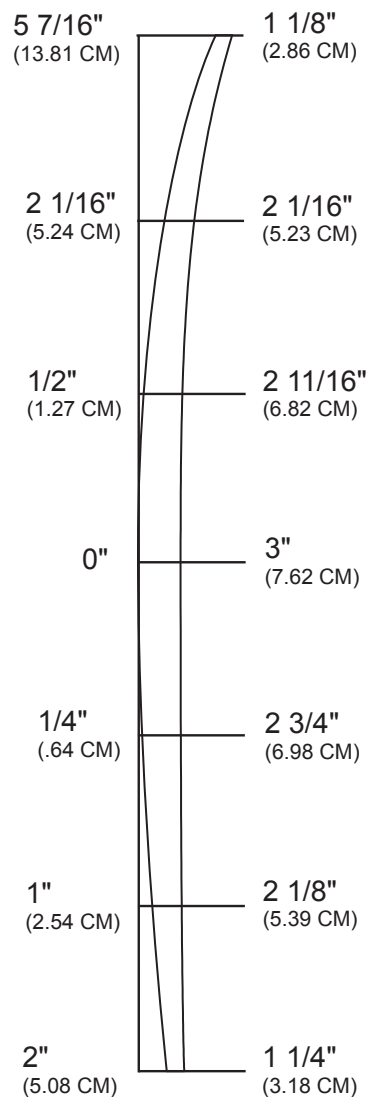

CENTER DECK SCALE CROSSSECTION



MILLENNIUM
FOAM  BUILD ON QUALITY

ORDER@MILLENNIUMFOAM.COM
310.323.5386

6'2"DE

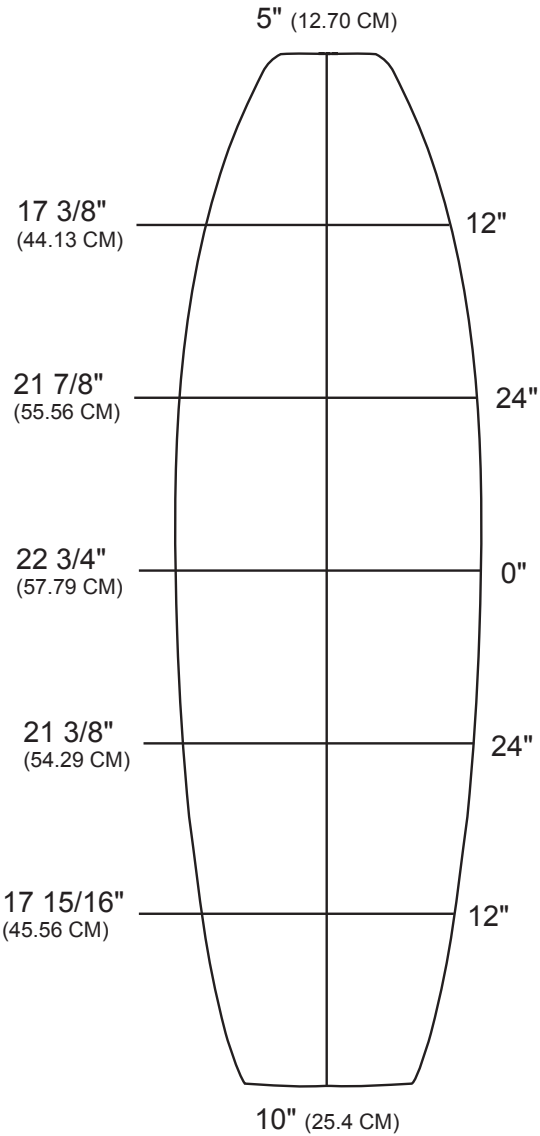

BOTTOM LENGTH: 6' 2 3/8"
(188.91 CM)

TIP TO TIP DECK: 6' 1 3/4"
(187.32 CM)

MAX WIDTH: 22 3/4" (57.79 CM)

MAX THICKNESS: 2 3/4" (6.98 CM)

COMMENTS:
THIS BLANK IS IDEAL FOR
SMALLER FISH, AND QUADS,
AND ROCKET FISHES.
DESIGNED FOR THE
HANDSHAPER. WITH PROPER
ROCKER CAN BE MACHINED

VOLUME: 48.5L

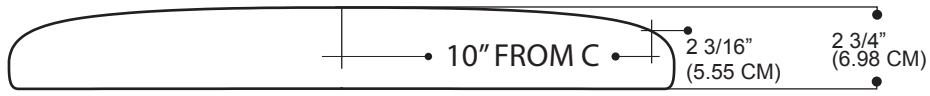
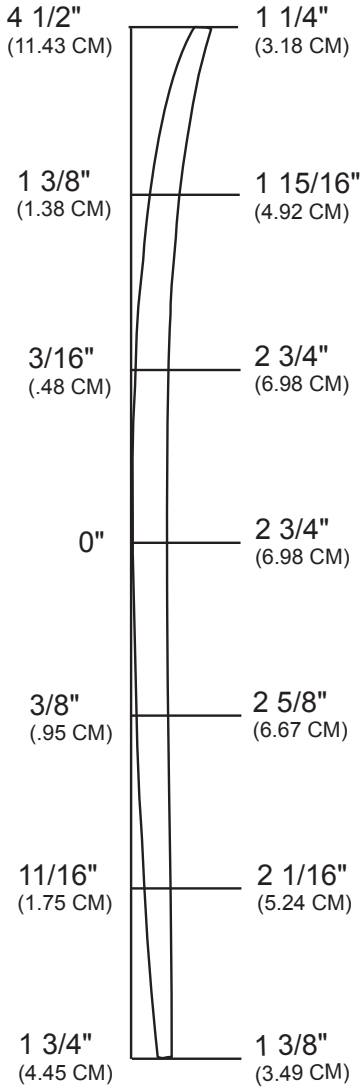

CENTER DECK SCALE CROSSECTION

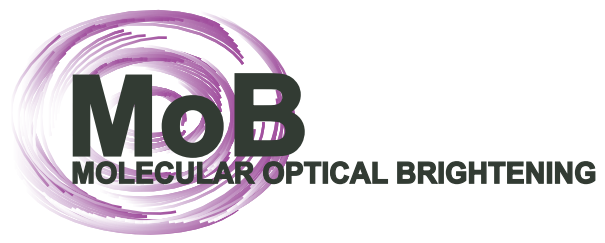

MILLENNIUM
FOAM BUILD ON QUALITY

ORDER@MILLENNIUMFOAM.COM
310.323.5386

6'2"DT

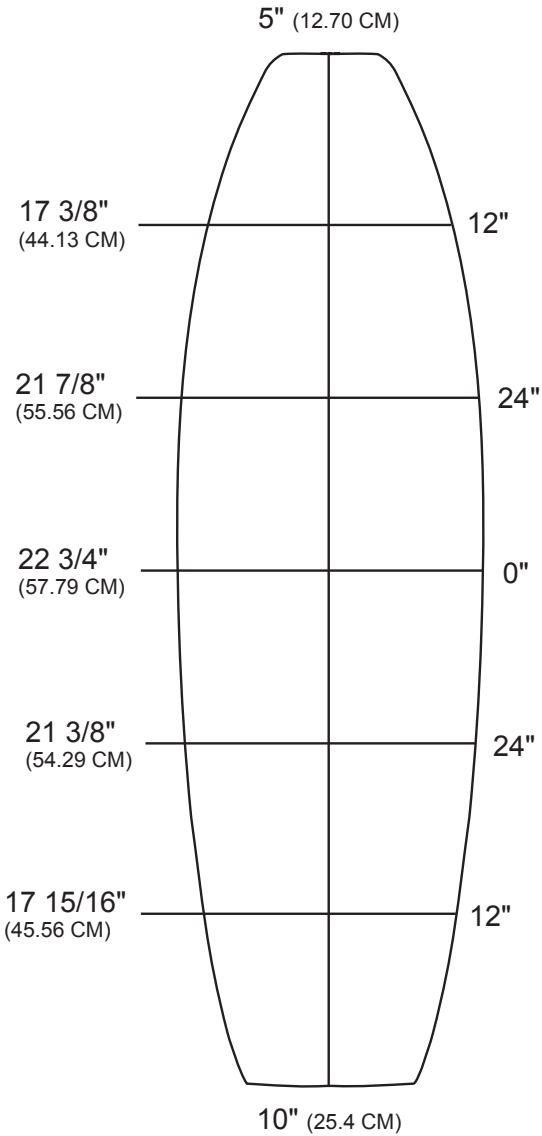

BOTTOM LENGTH: 6' 2 3/8"
(188.91 CM)

TIP TO TIP DECK: 6' 1 3/4"
(187.32 CM)

MAX WIDTH: 22 3/4" (57.79 CM)

MAX THICKNESS: 3" (6.62 CM)

COMMENTS:
THIS BLANK IS IDEAL FOR SMALLER FISH, AND QUADS, AND ROCKET FISHES.
THIS BLANK IS A RESULT OF MANY REQUESTS FOR OUR 6'2" DE IN A THICKER, MORE CURRENT MACHINE FRIENDLY PROFILE

VOLUME: 53.5L

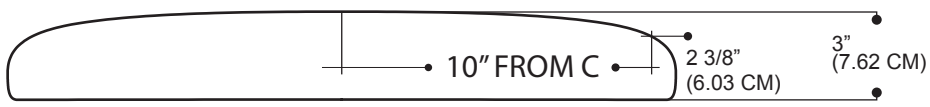
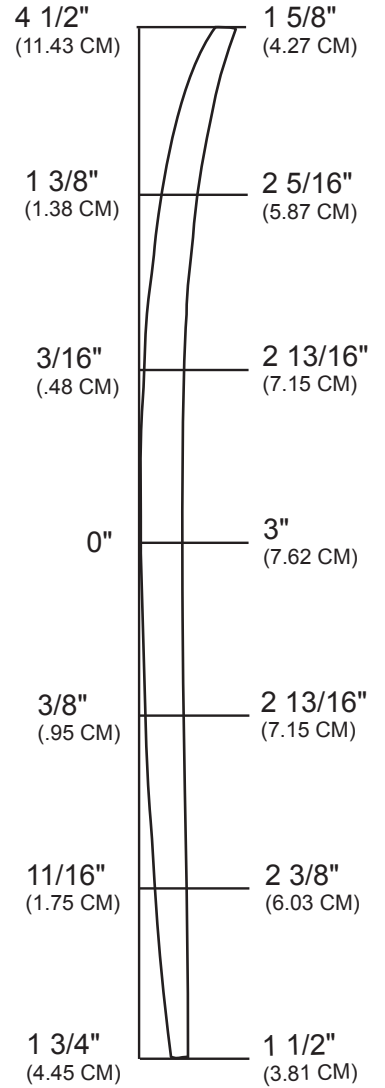

CENTER DECK SCALE CROSSECTION



MILLENNIUM
FOAM BUILD ON QUALITY

ORDER@MILLENNIUMFOAM.COM
310.323.5386

6'3"CB

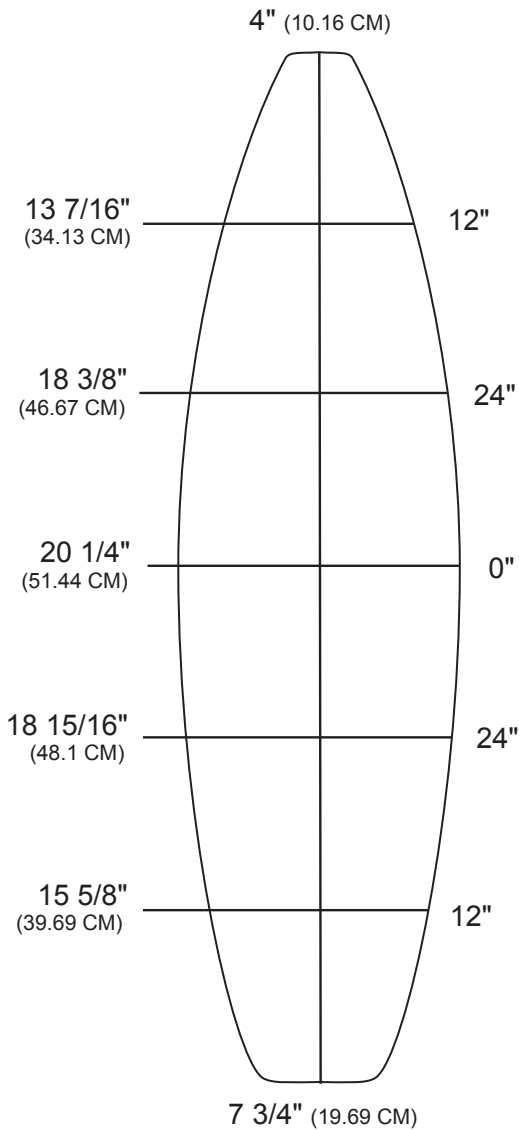

BOTTOM LENGTH: 6' 4" (193.04 CM)

TIP TO TIP DECK: 6' 2" (187.96 CM)

MAX WIDTH: 20 1/4" (51.44 CM)

MAX THICKNESS: 2 13/16" (7.14 CM)

SHAPED BY: CHRIS BORST,

SEPTEMBER 2006

COMMENTS:
THIS IS THE SECOND IN THE "CB" SHORTBOARD LINE. DESIGNED TO COMPLEMENT THE 6'0"CB, AND THE 6'6"CB. A CLOSE TOLERANCE, MODERN SHORTBOARD BLANK. DESIGNED FOR HIGH PERFORMANCE SURFING.

VOLUME: 40.6L

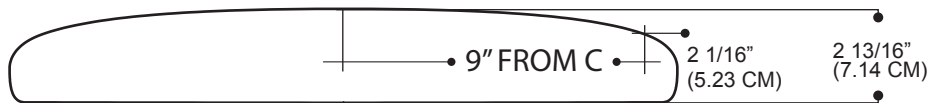
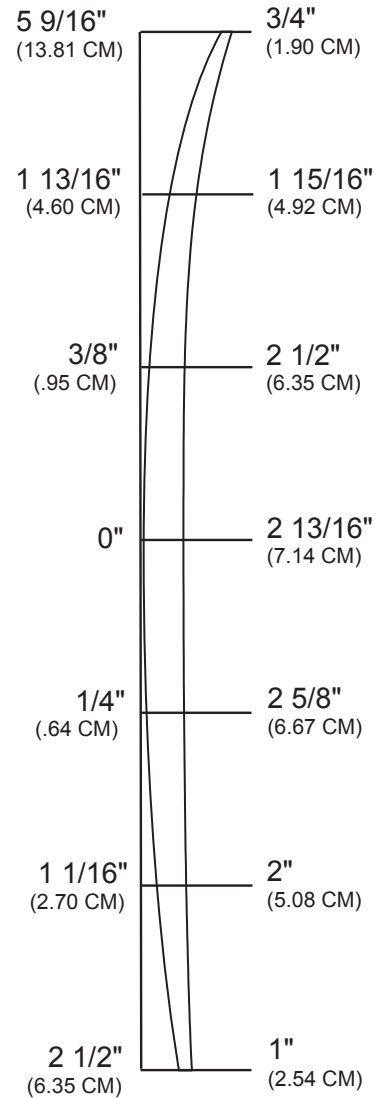

CENTER DECK SCALE CROSSSECTION

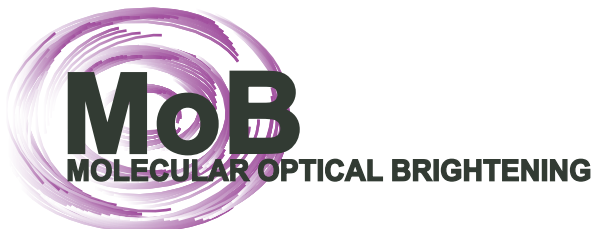

MILLENNIUM
FOAM  BUILD ON QUALITY

ORDER@MILLENNIUMFOAM.COM
310.323.5386

6'3" DG

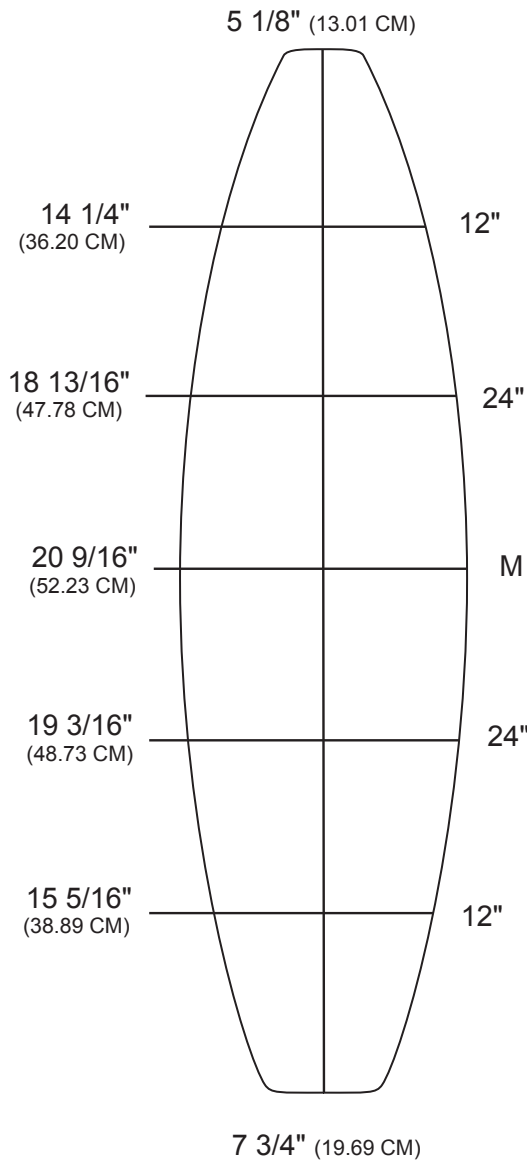

BOTTOM LENGTH: 6' 3 9/16"
(192 CM)

TIP TO TIP DECK: 6' 2 3/4"
(189.9 CM)

MAX WIDTH: 20 9/16" (52.23 CM)

MAX THICKNESS: 2 13/16"
(7.14 CM)

COMMENTS:
BLANK DESIGNED FOR MACHINE CUTTING. CARRIES EXTRA THICKNESS YET DECK IS NOT COMPLETELY FLAT. SOME CROWN IN DECK TOWARDS RAILS STILL ALLOWS VIABILITY IN HANDSHAPING AS WELL.

VOLUME: 43.4L

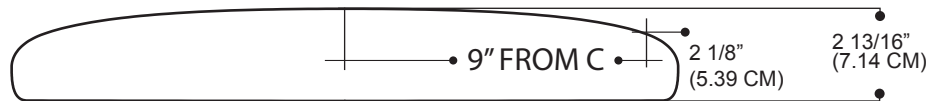
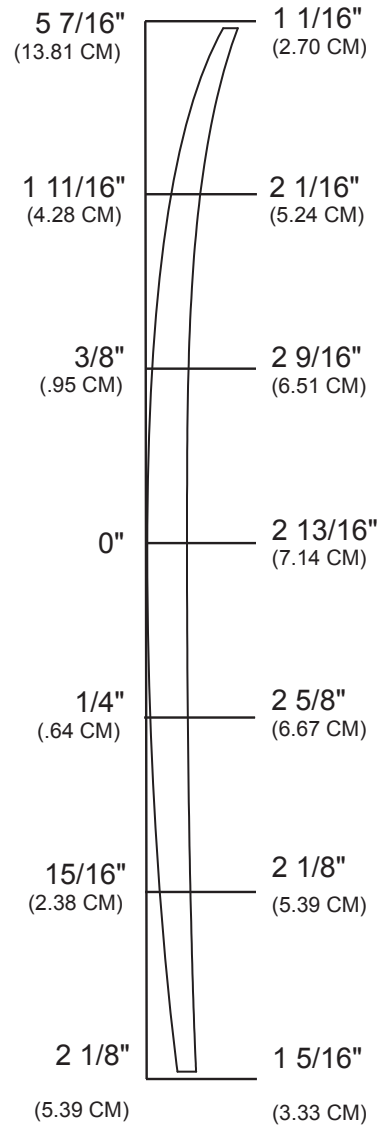

CENTER DECK SCALE CROSSSECTION

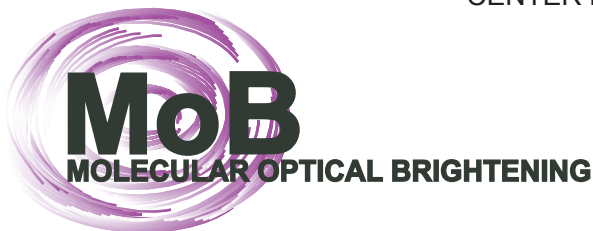

MILLENNIUM
FOAM  **BUILD ON QUALITY**

ORDER@MILLENNIUMFOAM.COM
310.323.5386

6'3" S

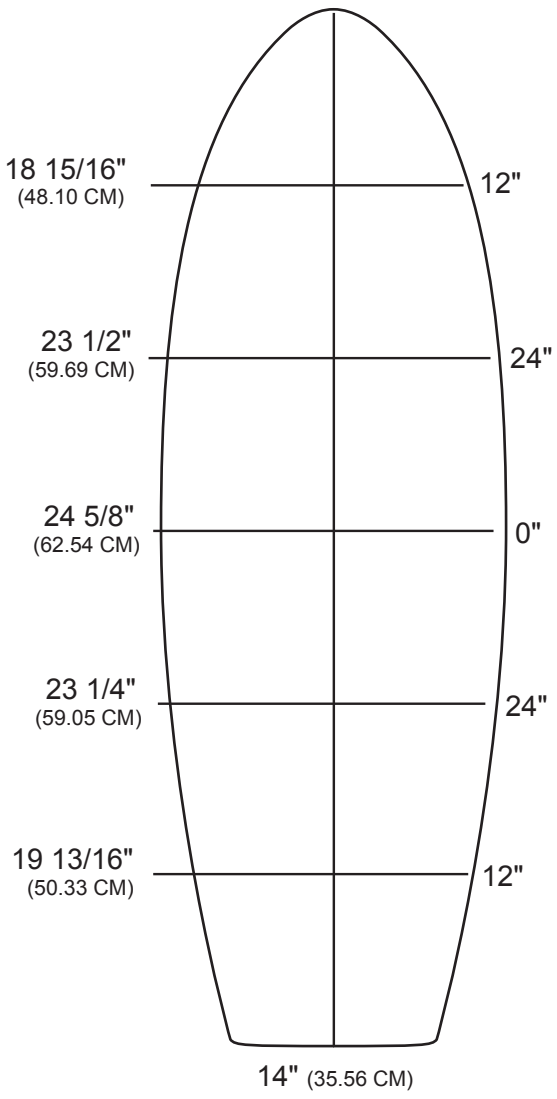

BOTTOM LENGTH: 6' 3 1/4"
(191.3 CM)

TIP TO TIP DECK: 6' 2 3/4"
(189.86 CM)

MAX WIDTH: 24 5/8" (62.54 CM)

MAX THICKNESS: 3 5/16" (8.41 CM)

SHAPED BY: STEVE SEEBOLD
OCTOBER 2006

COMMENTS:
THIS BLANK WAS DESIGNED FOR THE TRADITIONAL FISH. THE ROCKER IS RELAXED AND THICKNESS IS STILL CARRIED TO THE RAILS. SHAPERS WILL BE ABLE TO GET A CLASSIC BOXY RAIL.

VOLUME: 62.8L

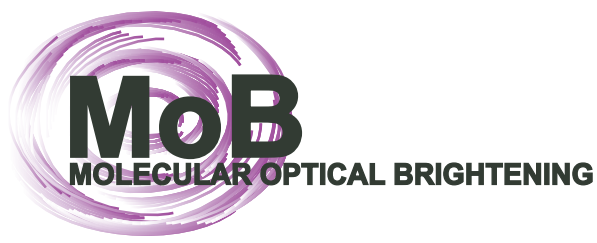
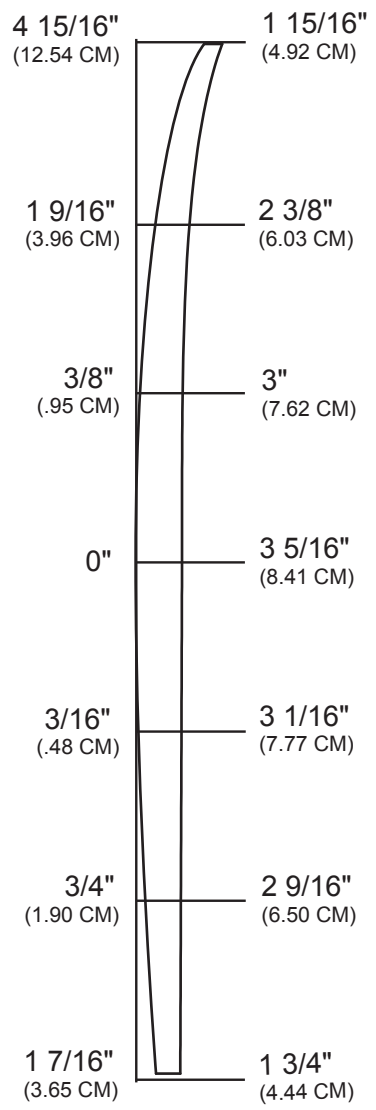

MILLENNIUM
FOAM  **BUILD ON QUALITY**

ORDER@MILLENNIUMFOAM.COM
310.323.5386

6'4" A

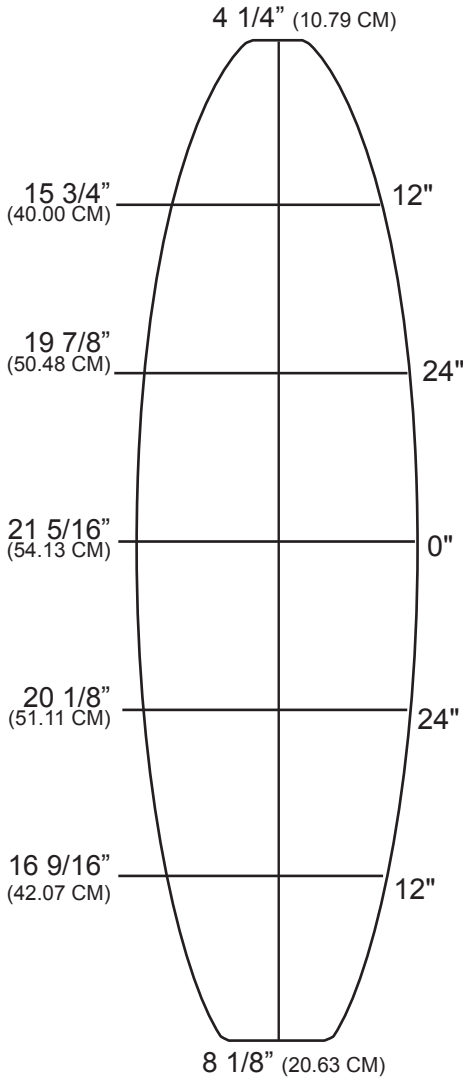

BOTTOM LENGTH: 6' 4 15/16"
(195.42 CM)

TIP TO TIP LENGTH: 6' 4"
(193.04 CM)

MAX WIDTH: 21 5/16" (54.13 CM)

THE 64A IS THE SECOND IN OUR NEW 'A' SERIES OF BLANKS. THEY ARE WIDER AND FULLER THEN OUR STANDARD 'DG' SHORTBOARD BLANKS. THE WIDTH IS ADDED THROUGHT AND THE THICKNESS IS CARRIED TO THE RAIL BANDS. THE 64A WILL ACCOMMODATE THE NEW TREND OF WIDER AND THICKER SHORTBOARDS.

VOLUME: 52.7 L

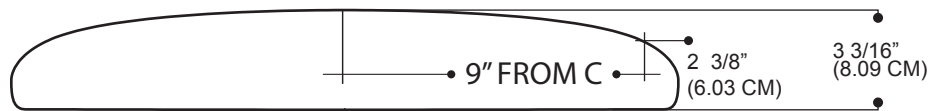
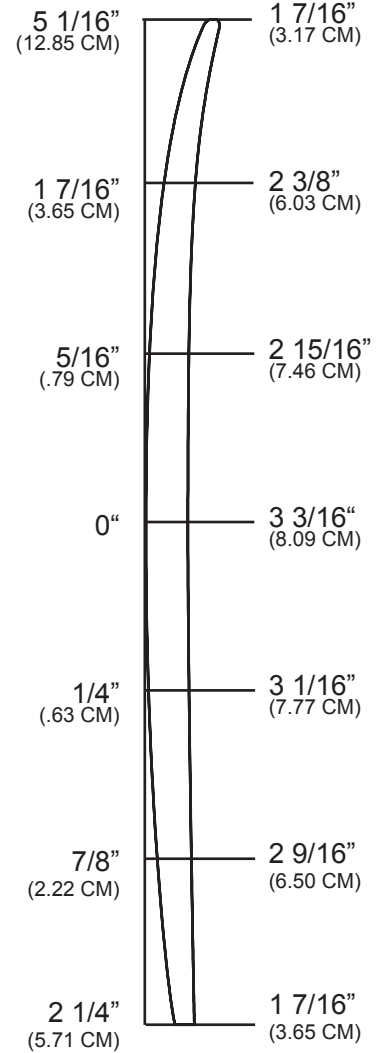

CENTER DECK CROSSECTION VIEW

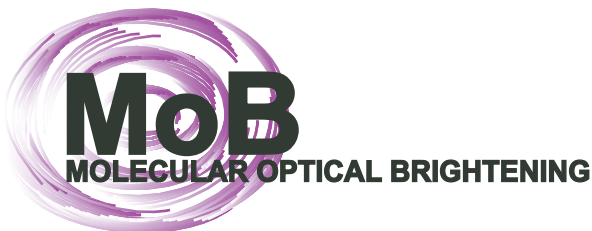

MILLENNIUM
FOAM  BUILD ON QUALITY

ORDER@MILLENNIUMFOAM.COM
310.323.5386

6'4"CT

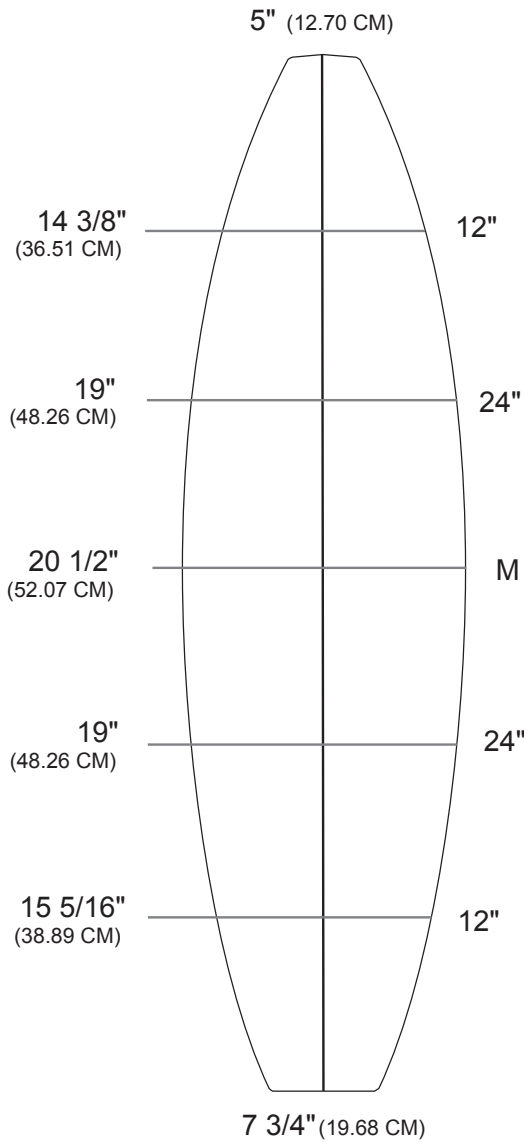

BOTTOM LENGTH: 6' 3 3/4"
(192.5 CM)

TIP TO TIP DECK: 6' 2 13/16"
(190 CM)

MAX WIDTH: 20 1/2" (52.07 CM)

MAX THICKNESS: 3 1/8" (7.93 CM)

COMMENTS:
THIS IS THE THICKER VERSION OF THE 64C. THE 64C, BASED CUSTOMER FEEDBACK, WAS SOMETIMES TOO THIN. THE 64CT HAS ADDED THICKNESS AND VOLUME. THE ROCKER HAS BEEN MODERNIZED AS WELL FROM THE PREVIOUS RELAXED NATURAL AND HAS THE NEW 2014 VERSION.

VOLUME: 48.2 L

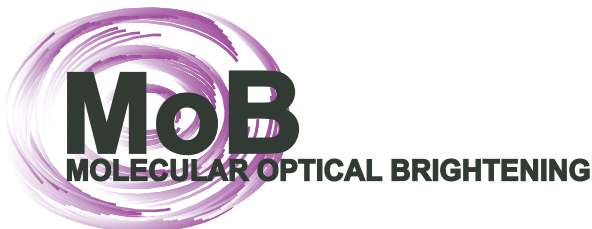
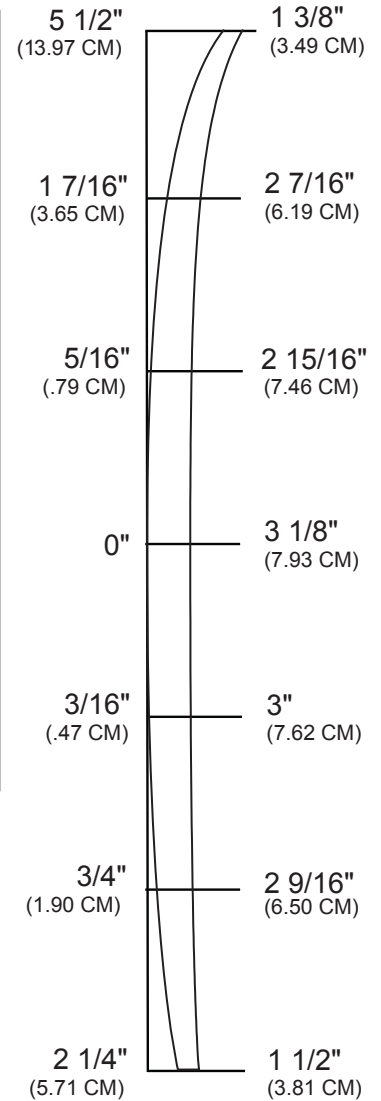

MILLENNIUM
FOAM  BUILD ON QUALITY

ORDER@MILLENNIUMFOAM.COM
310.323.5386

6'5"F

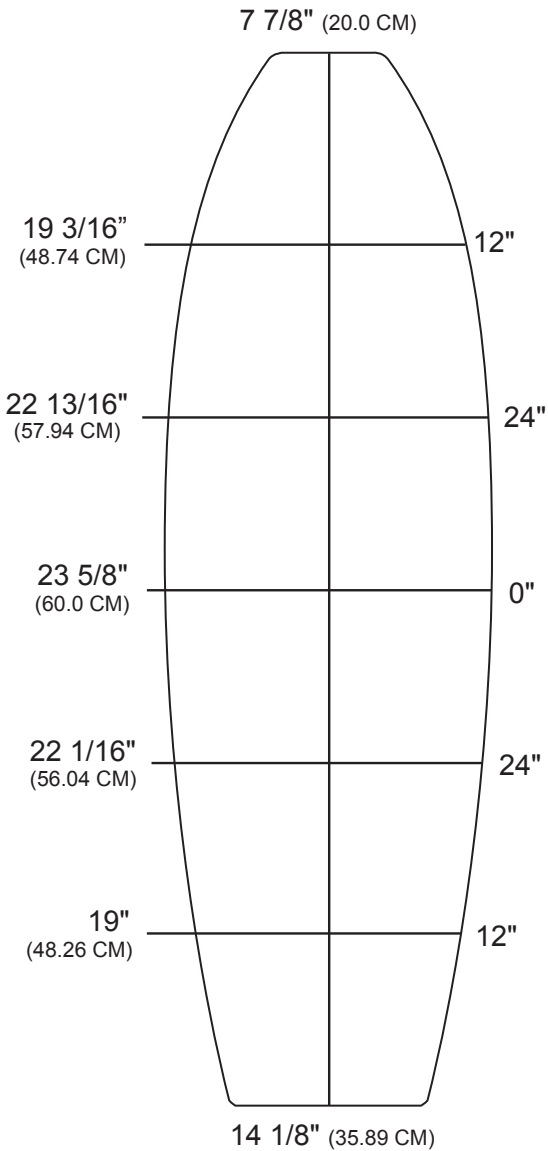

BOTTOM LENGTH: 6' 4 5/8"
(194.63 CM)

TIP TO TIP DECK: 6' 4" (193.0 CM)

MAX WIDTH: 23 5/8" (60.0 CM)

MAX THICKNESS: 3 1/8" (7.93 CM)

GENERAL PURPOSE FISH BLANK.
GRADUAL ROCKER CURVE
ALLOWS FLEXABILITY, WHILE
DECK PROFILE MAKES FOR
EASY HAND SHAING.

VOLUME: 61.0L

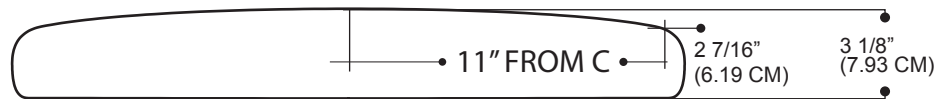
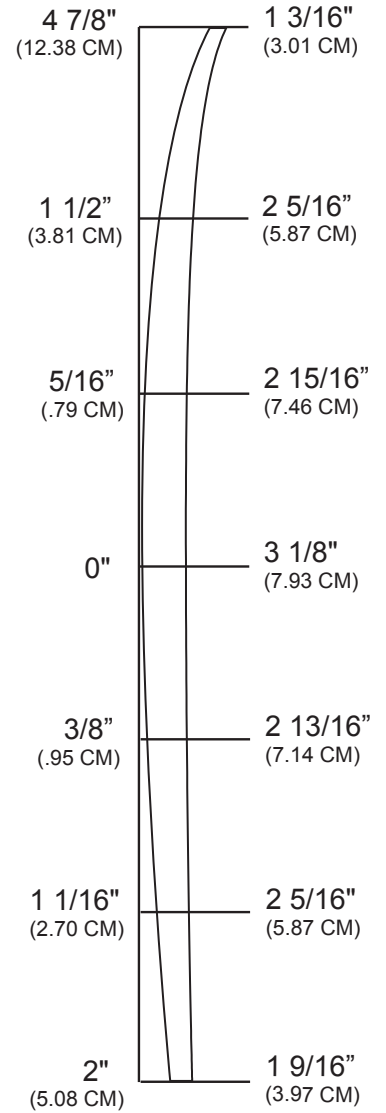

CENTER DECK CROSSECTION VIEW

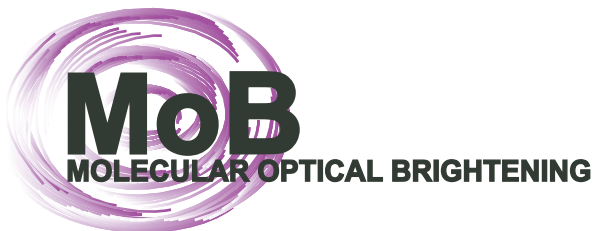

MILLENNIUM
FOAM  BUILD ON QUALITY

ORDER@MILLENNIUMFOAM.COM
310.323.5386

6'6"CB

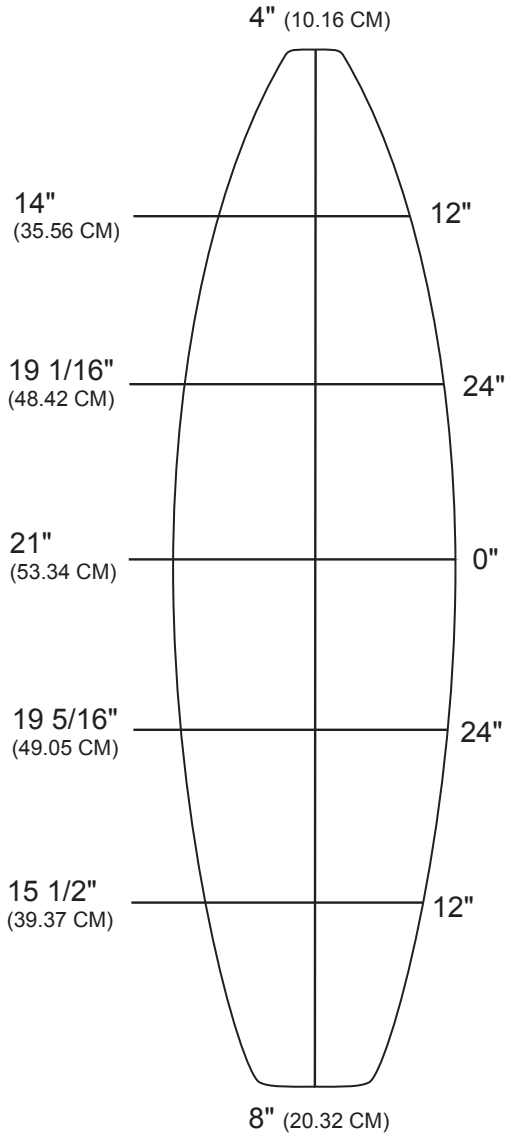

BOTTOM LENGTH: 6' 5 7/8" (197.7 CM)

TIP TO TIP DECK: 6' 5 3/16" (196 CM)

MAX WIDTH: 21" (53.34 CM)

MAX THICKNESS: 2 5/8" (6.67 CM)

SHAPED BY: CHRIS BORST,
DECEMBER 2006

COMMENTS:
THIS PLUG HAS THE HANDSHAPER IN MIND. IT IS A CONTINUATION OF MY "CB" CLOSE TOLERANCE SHORTBOARD LINE. THE ROCKER IS GRADUAL AND THE THICKNESS MAKES FOR EASY SHAPING.

VOLUME: 39.8L

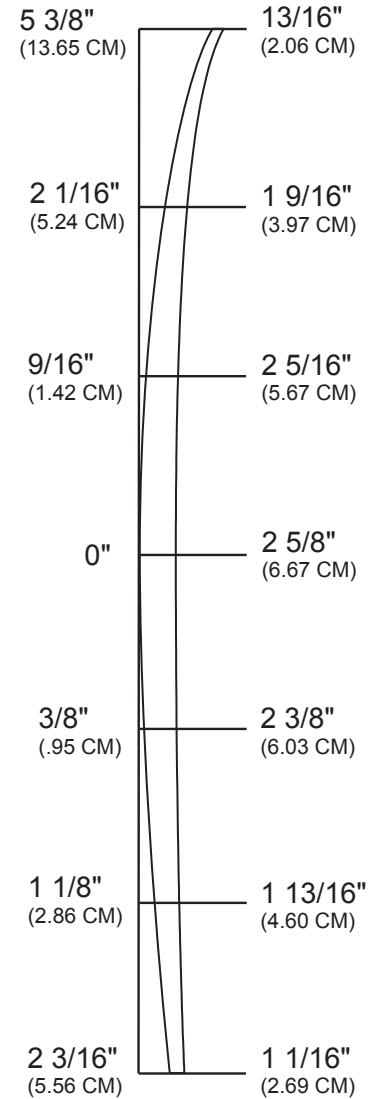

CENTER DECK CROSSECTION VIEW

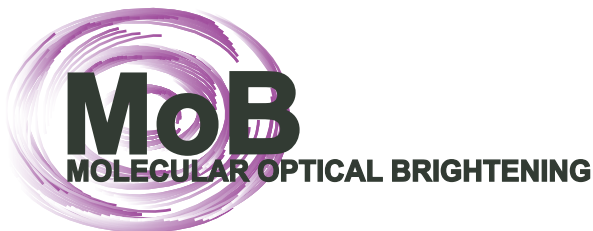

MILLENNIUM
FOAM  BUILD ON QUALITY

ORDER@MILLENNIUMFOAM.COM
310.323.5386

6'6" DG

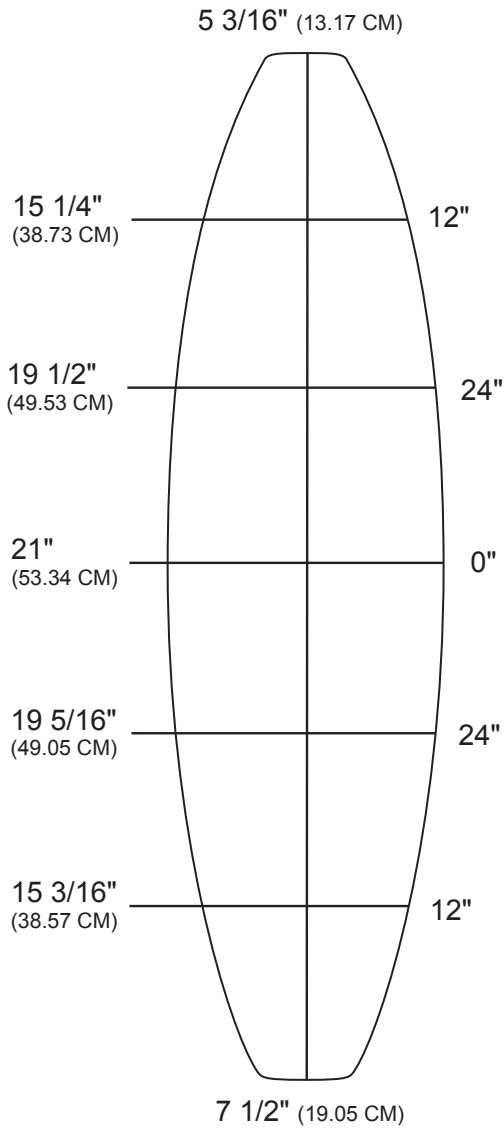

BOTTOM LENGTH: 6' 6 1/8" (198.5 CM)

TIP TO TIP DECK: 6' 5 1/2" (196.9 CM)

MAX WIDTH: 21" (53.34 CM)

MAX THICKNESS: 2 7/8" (7.30 CM)

BLANK DESIGNED FOR MACHINE CUTTING. CARRIES EXTRA THICKNESS, AND A FLATTER DECK. NATURAL ROCKER TENDS TO WORK WELL WITH MOST SHAPES

VOLUME: 45.3L

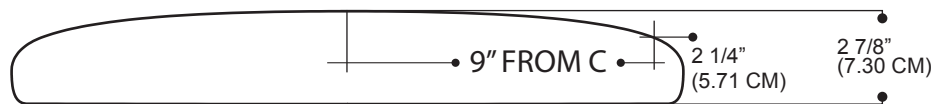
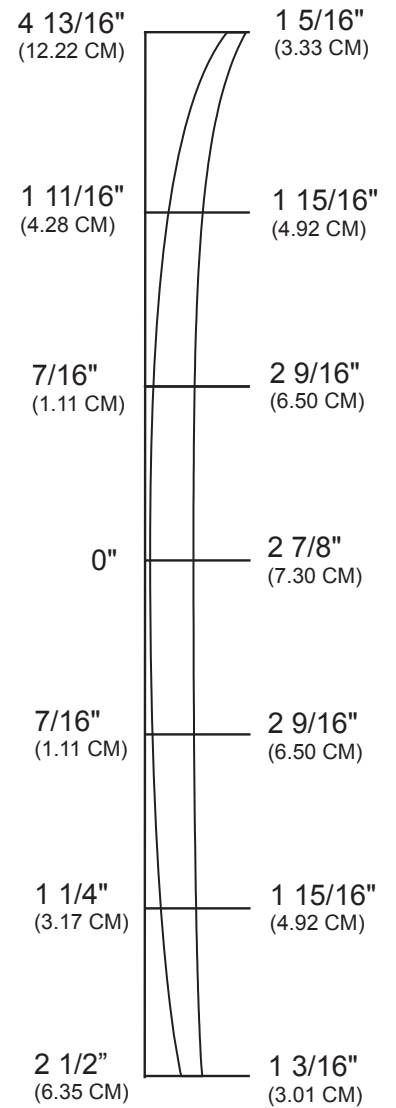

CENTER DECK CROSSECTION VIEW

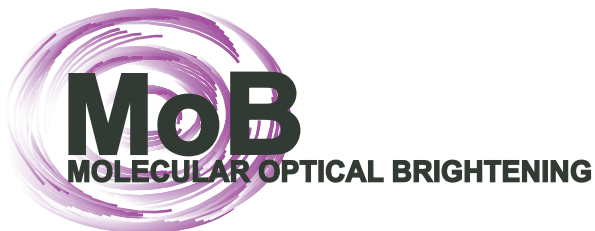

MILLENNIUM
FOAM  BUILD ON QUALITY

ORDER@MILLENNIUMFOAM.COM
310.323.5386

6'8" DG

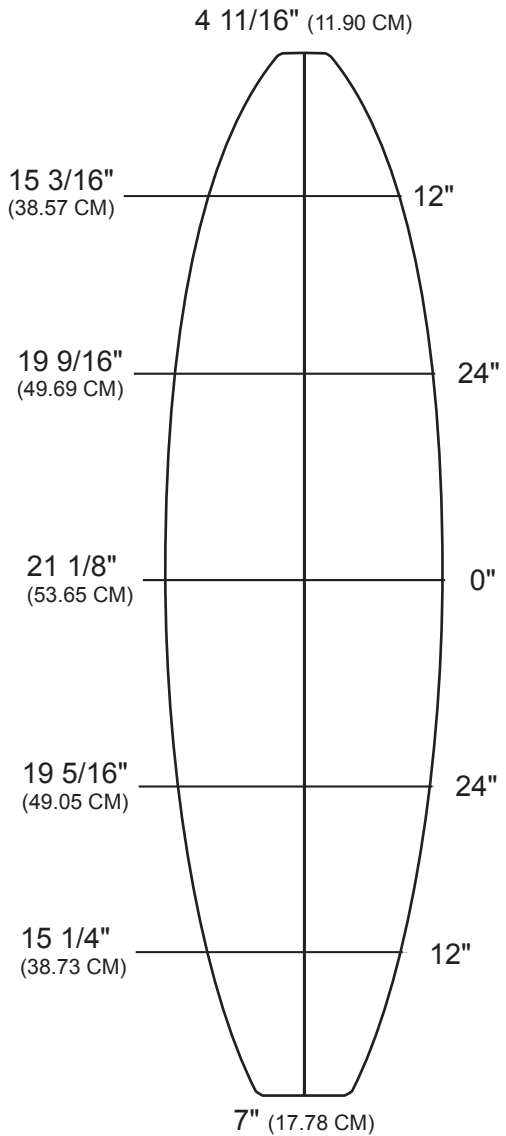

BOTTOM LENGTH: 6' 8 1/4"
(203.83 CM)

TIP TO TIP DECK: 6' 7 11/16"
(202.41 CM)

MAX WIDTH: 21 1/8" (53.65 CM)

MAX THICKNESS: 3 1/8" (7.93 CM)

BLANK DESIGNED FOR MACHINE CUTTING. EXTRA THICKNESS, AND FLATTER DECK. EXTRA VOLUME IS CARRIED TO THE RAILS TO PROVIDE OPTOINS FOR A WELL PROPORTIONED SHORTBOARD

VOLUME: 50.9L

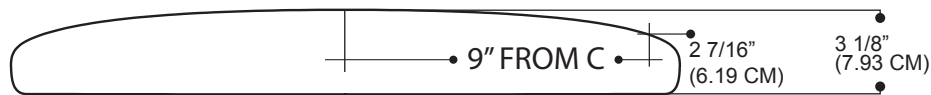
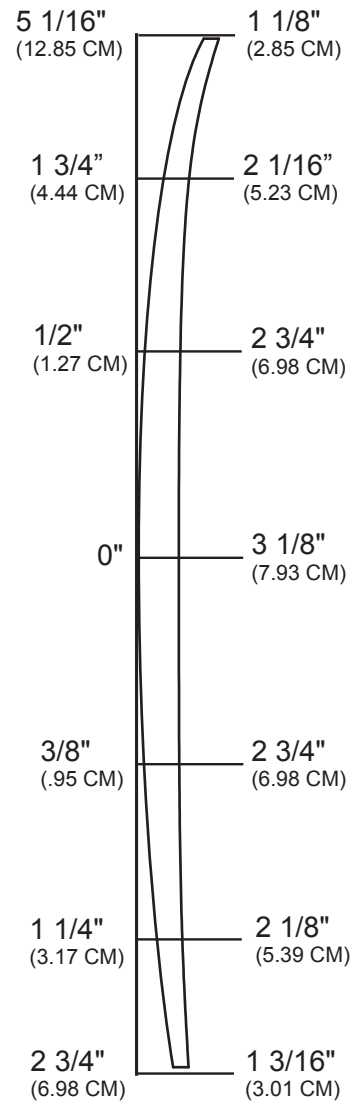

CENTER DECK CROSSECTION VIEW

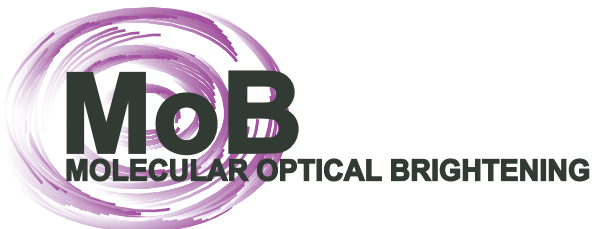

MILLENNIUM
FOAM  BUILD ON QUALITY

ORDER@MILLENNIUMFOAM.COM
310.323.5386

6'9" A

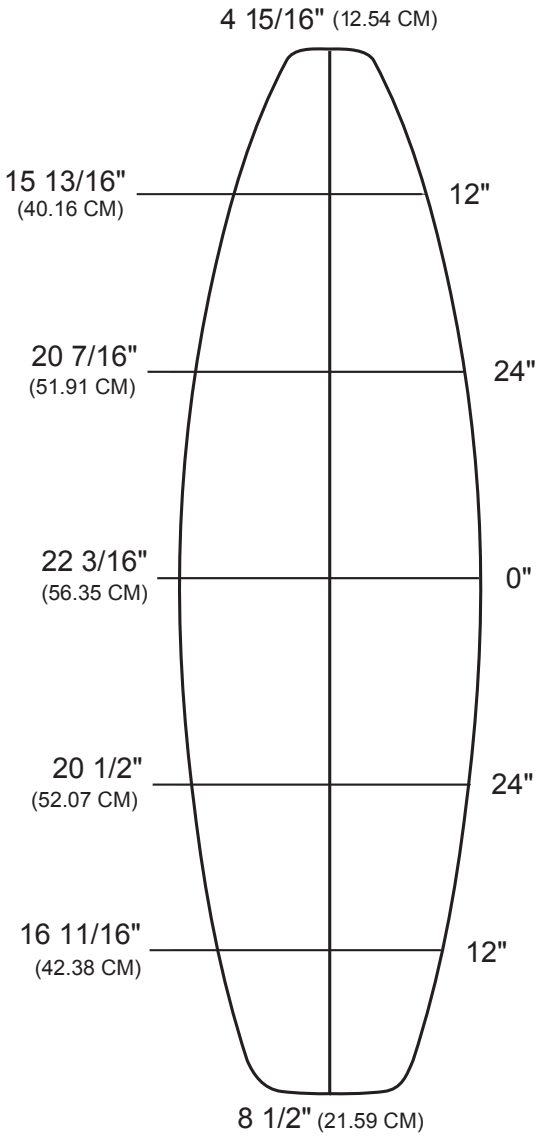

BOTTOM LENGTH: 6' 9 11/16"
(207.49 CM)

TIP TO TIP DECK: 6' 9"
(205.74 CM)

MAX WIDTH: 22 3/16" (56.35 CM)

MAX THICKNESS: 3 1/4" (8.25 CM)

THIS BLANK IS A REDESIGNED VERSION OF THE 68DG. THE WIDTH IN THE LAST HALF HAS BEEN INCREASED ALMOST 1". MORE VOLUME HAS BEEN ADDED TO THE RAIL BANDS. BOTH OF THOSE ADJUSTMENTS MAKE THIS BLANK EVEN MORE SUITED TO THE WIDER, THICKER RAILED SHORT BOARDS DESIGNS THAT ARE COMMON NOW.

VOLUME: 57.5L

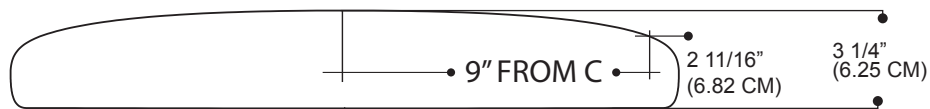
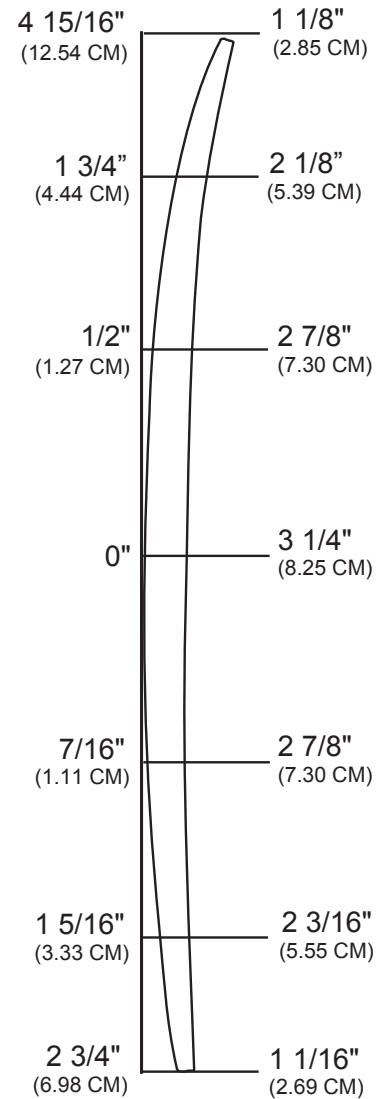

CENTER DECK CROSSSECTION VIEW

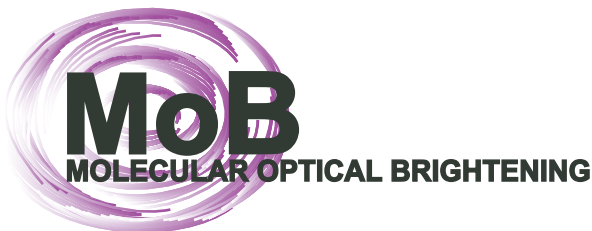

MILLENNIUM
FOAM  BUILD ON QUALITY

ORDER@MILLENNIUMFOAM.COM
310.323.5386

6'9" CB

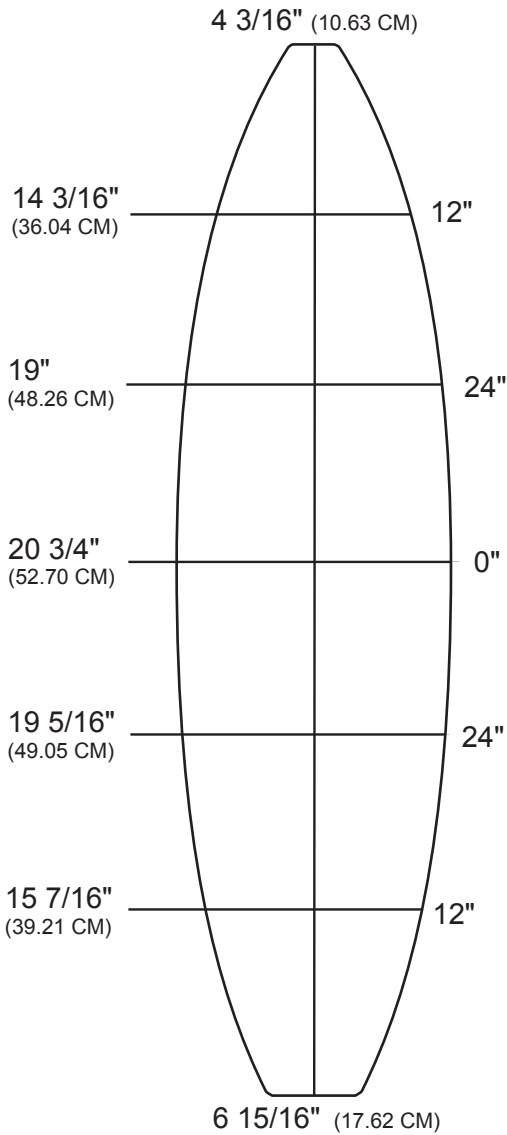

BOTTOM LENGTH: 6' 8 3/8"
(204.20 CM)

TIP TO TIP DECK: 6' 7 1/2"
(201.9 CM)

MAX WIDTH: 20 3/4" (52.70 CM)

MAX THICKNESS: 2 5/8" (6.66 cm)

SHAPED BY: CHRIS BORST,
DECEMBER 2006

COMMENTS:
THIS PLUG HAS THE
HANDSHAPER IN MIND. IT IS
THE LAST OF MY "CB" CLOSE
TOLERANCE SHORTBOARD
LINE. THE ROCKER IS
GRADUAL AND THE
THICKNESS MAKES FOR EASY
SHAPING.

VOLUME: 41.1 L

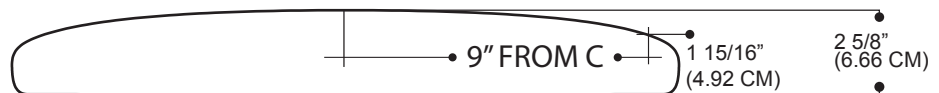
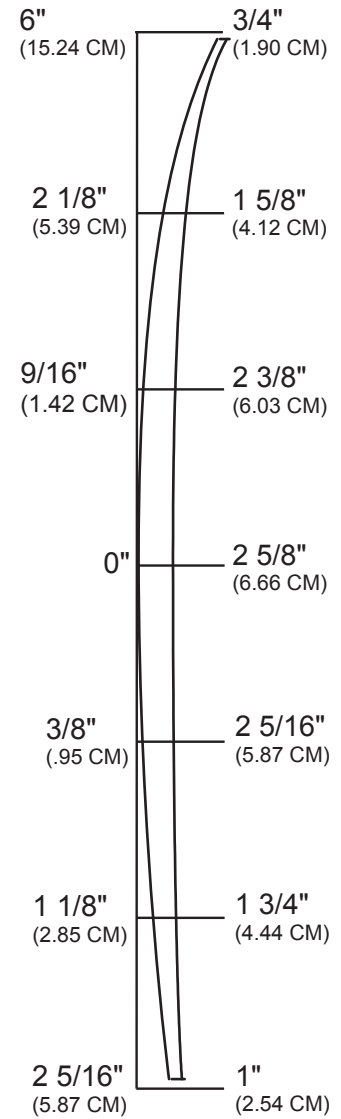

CENTER DECK CROSSSECTION VIEW

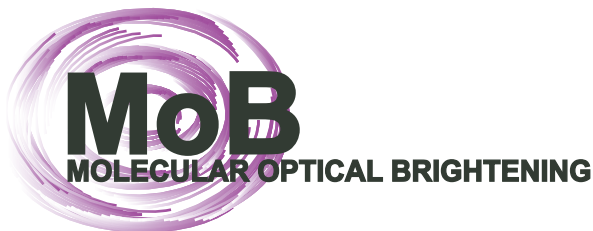

MILLENNIUM
FOAM  BUILD ON QUALITY

ORDER@MILLENNIUMFOAM.COM
310.323.5386

6'10"M

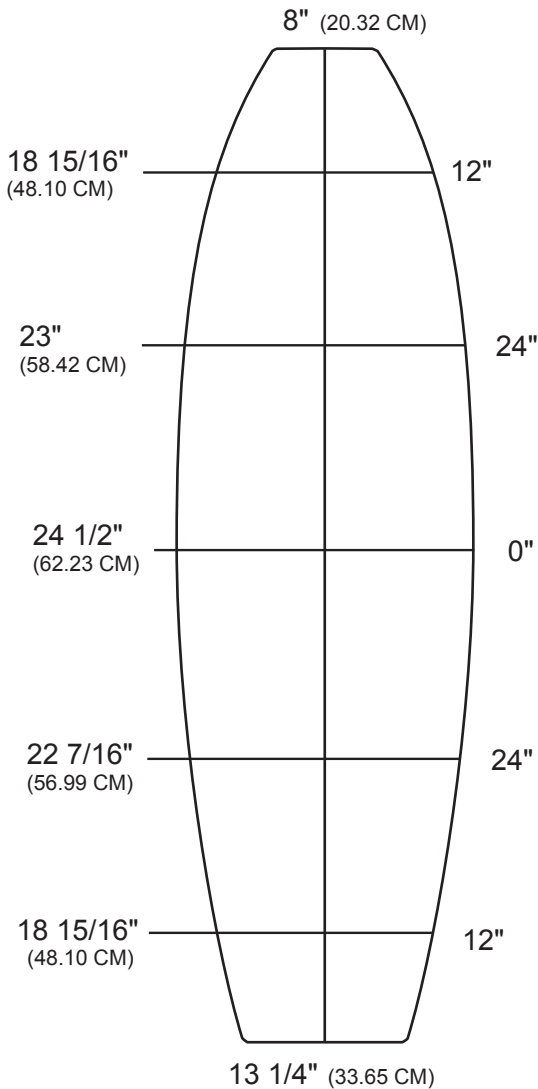

BOTTOM LENGTH: 6' 10 1/2"

(209.5 CM)

TIP TO TIP DECK: 6' 10" (208.3 CM)

MAX WIDTH: 24 1/2" (62.23 CM)

MAX THICKNESS: 3 1/8" (7.94 CM)

SHAPED BY: BOB MITSVEN
SEPTEMBER 2006

COMMENTS:
THIS BLANK IS DESIGNED FOR
THE LARGER SIZE FISH. THE
THICKNESS IS CARRIED TO
THE RAIL, AND A CONSISTENT
VOLUME FROM NOSE TO TAIL
HAS BEEN ADDED. THE
ROCKER IS LOWERED IN THE
NOSE FOR EASY ENTRY
ROCKER, AND ADJUSTMENT.

VOLUME: 66.02L

WIRE FRAME BLANK MAP NOT TO SCALE

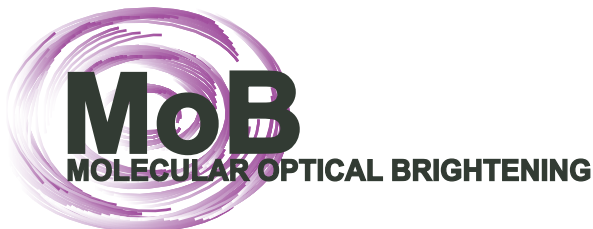
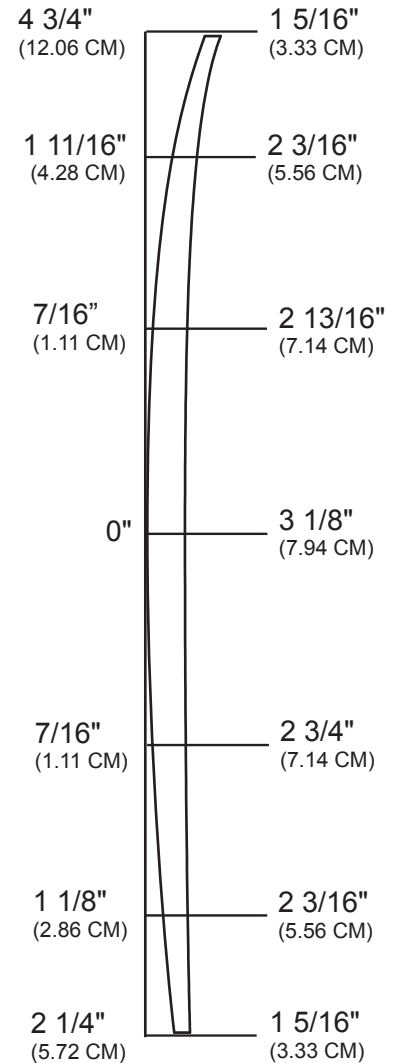

MILLENNIUM
FOAM  BUILD ON QUALITY

ORDER@MILLENNIUMFOAM.COM
310.323.5386

6'11" F

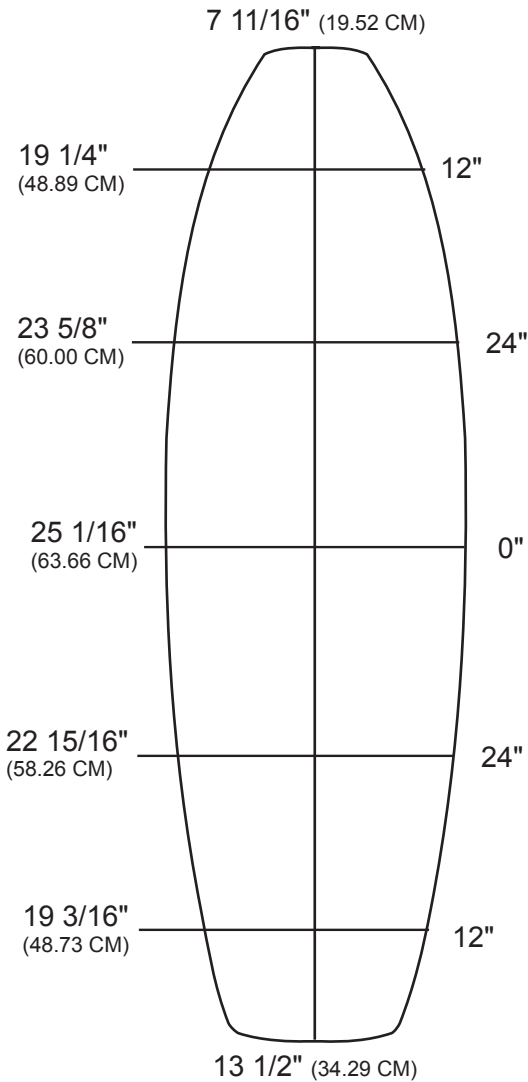

BOTTOM LENGTH: 6' 10 1/4"
(208.91 CM)

TIP TO TIP DECK: 6' 9 1/8"
(206.06 CM)

MAX WIDTH: 25 1/16" (63.66 CM)

MAX THICKNESS: 3 1/2" (8.89 CM)

COMMENTS:
THIS BLANK IS DESIGNED FOR
THE LARGER AND FULLER
SIZE FISH. THE THICKNESS IS
CARRIED TO THE RAIL, AND
CREATES A VERSATILE BLANK
FOR LARGER VOLUME
BOARDS. THIS BLANK HAS
GREATER THICKNESS AND
WIDTH THEN THE 610M FISH
BLANK.

VOLUME: 70.7L

WIRE FRAME BLANK MAP NOT TO SCALE

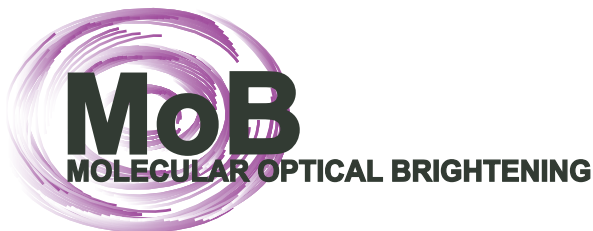
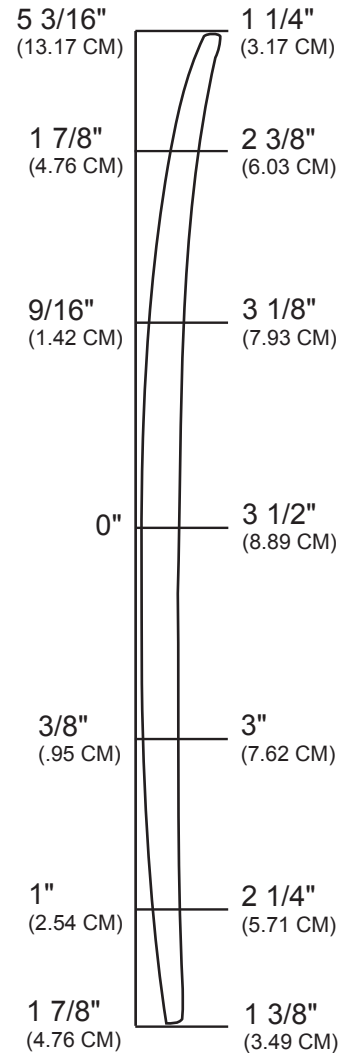

MILLENNIUM
FOAM  BUILD ON QUALITY

ORDER@MILLENNIUMFOAM.COM
310.323.5386

6'11" M

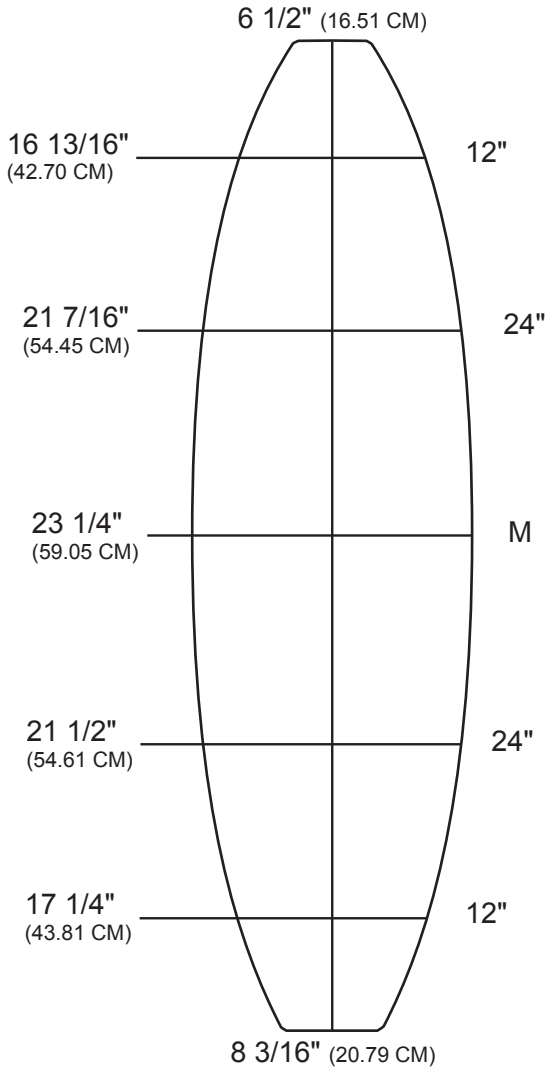

BOTTOM LENGTH: 6' 11 1/8" (211.14 CM)

TIP TO TIP DECK: 6' 10" (208.28 CM)

MAX WIDTH: 23 1/4" (59.05 CM)

MAX THICKNESS: 3" (7.62 CM)

SHAPED BY: BOB MITSVEN
AUGUST 2006

COMMENTS: THIS IS BASED ON MY EXPERIENCE SHAPING THE 6.11R. THE CHANGES REFLECT A VERSATILE BLANK. I'VE ADDED WIDTH, THICKNESS, AND CARRIED SOME ADDED VOLUME OUT TO THE RAIL. THIS BLANK IS IDEAL FOR, HYBRIDS, AND BIG GUY SHORTBOARDS.

VOLUME: 57.39L

WIRE FRAME BLANK MAP NOT TO SCALE

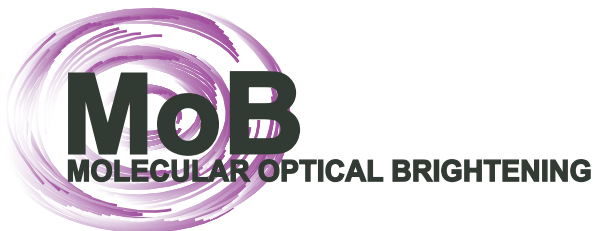
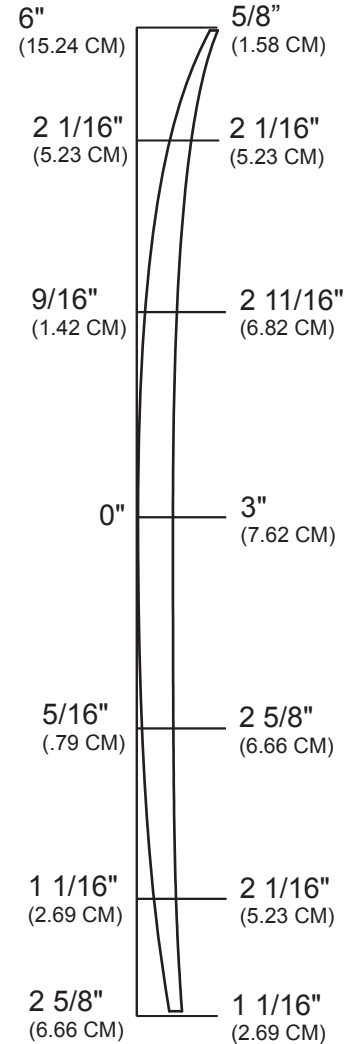

MILLENNIUM
FOAM  BUILD ON QUALITY

ORDER@MILLENNIUMFOAM.COM
310.323.5386

7'1" DG

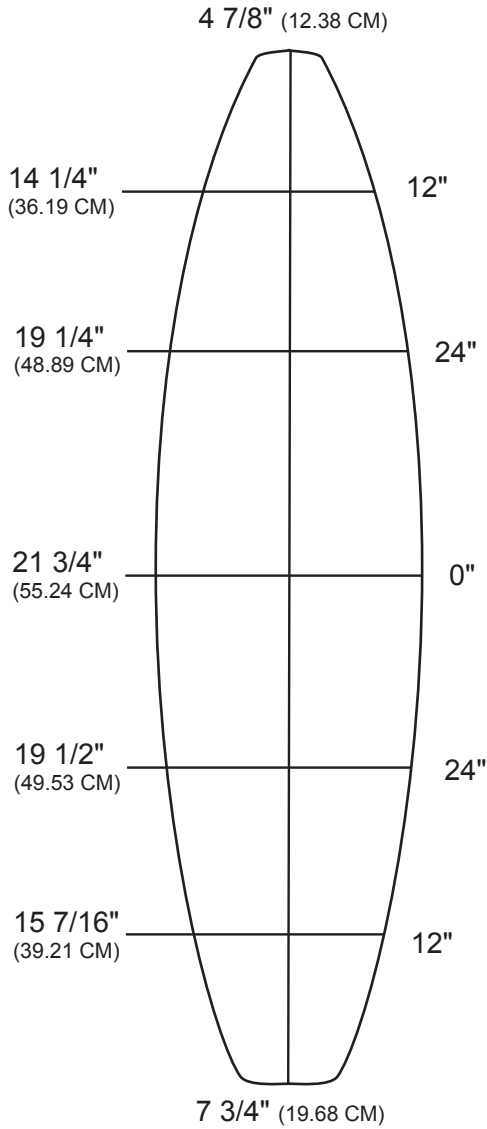

BOTTOM LENGTH: 7' 1 1/2"
(217.2 CM)

TIP TO TIP DECK: 7' 0" (213.4 CM)

MAX WIDTH: 21 3/4" (55.24 CM)

MAX THICKNESS: 3 3/16"
(7.78 CM)

BLANK DESIGNED FOR MACHINE CUTTING. EXTRA THICKNESS. IDEAL FOR LARGER SHORTBOARDS, AND BIG GUY TRI'S. ALTHOUGH FULL THICKNESS PROFILE IS CARRIED TO RAILS, DECK IS NOT EXCESSIVELY FLAT

VOLUME: 56.0L

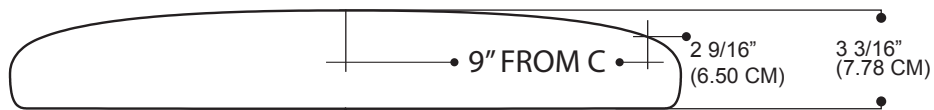
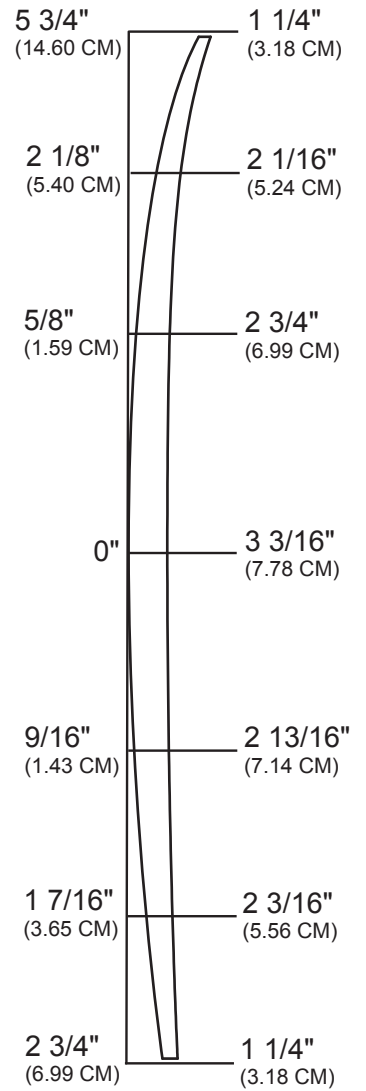

CENTER DECK CROSSECTION VIEW



MILLENNIUM
FOAM  BUILD ON QUALITY

ORDER@MILLENNIUMFOAM.COM
310.323.5386

7'3" DG

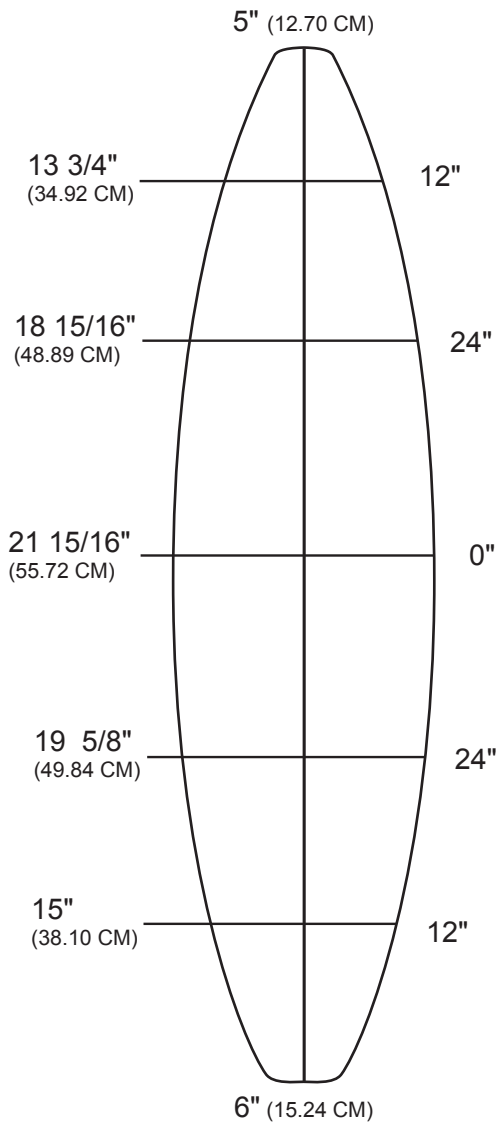

BOTTOM LENGTH: 7' 4 1/4" (224.2 CM)

TIP TO TIP DECK: 7' 3 1/4" (221.6 CM)

MAX WIDTH: 21 1/2" (55.72 CM)

MAX THICKNESS: 3 5/16" (8.41 CM)

BLANK DESIGNED FOR MACHINE CUTTING. AND CARRIES EXTRA THICKNESS. SMALLER GUNS AND BIG GUY

VOLUME: 60.5L

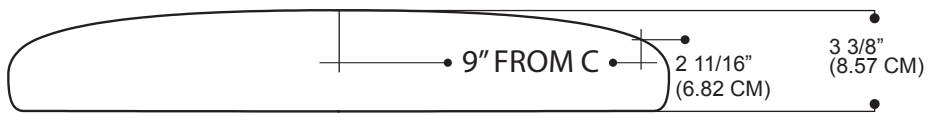
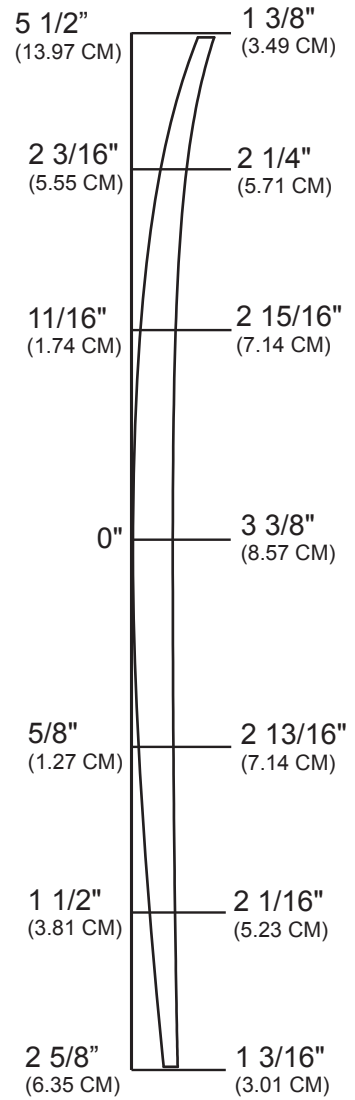

CENTER DECK CROSSSECTION VIEW

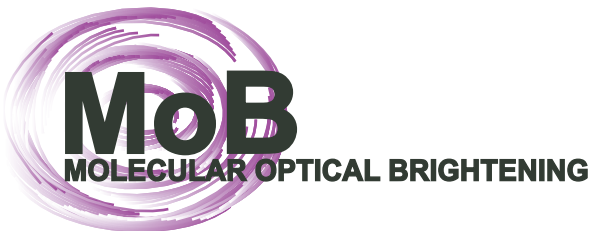

MILLENNIUM
FOAM  BUILD ON QUALITY

ORDER@MILLENNIUMFOAM.COM
310.323.5386

7'5"HS

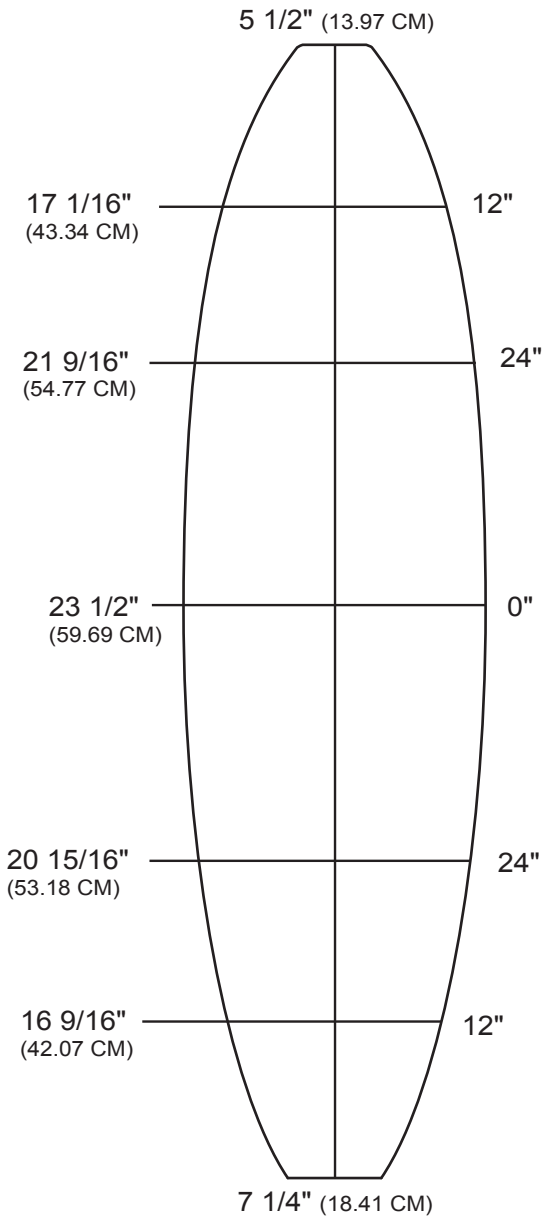

BOTTOM LENGTH: 7' 4 7/8"
(225.74 CM)

TIP TO TIP DECK: 7' 4" (223.52 CM)

MAX WIDTH: 23 1/2" (59.69 CM)

MAX THICKNESS: 3 1/8" (7.93 CM)

BLANK IS WELL SUITED FOR MID-RANGE HYBRIDS AND EGG. VOLUME DISTRIBUTION IS SUITED FOR MACHINE, BUT CAN BE HANDSHAPED WITH LITTLE EXTRA EFFORT. THICKNESS IS CARRIED TO RAIL BANDS

VOLUME: 65.94L

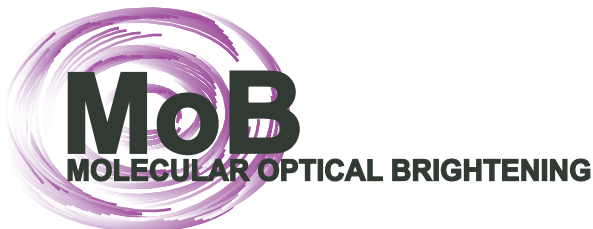
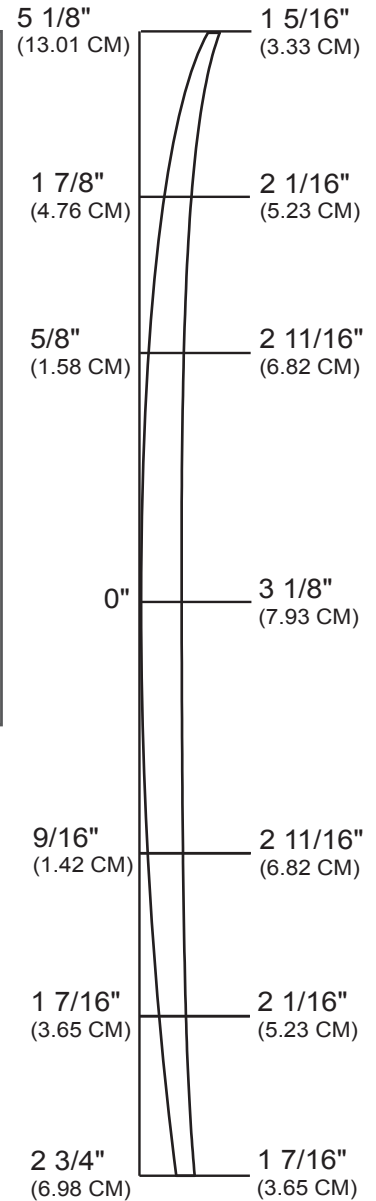

MILLENNIUM
FOAM  **BUILD ON QUALITY**

ORDER@MILLENNIUMFOAM.COM
310.323.5386

7'10" DG

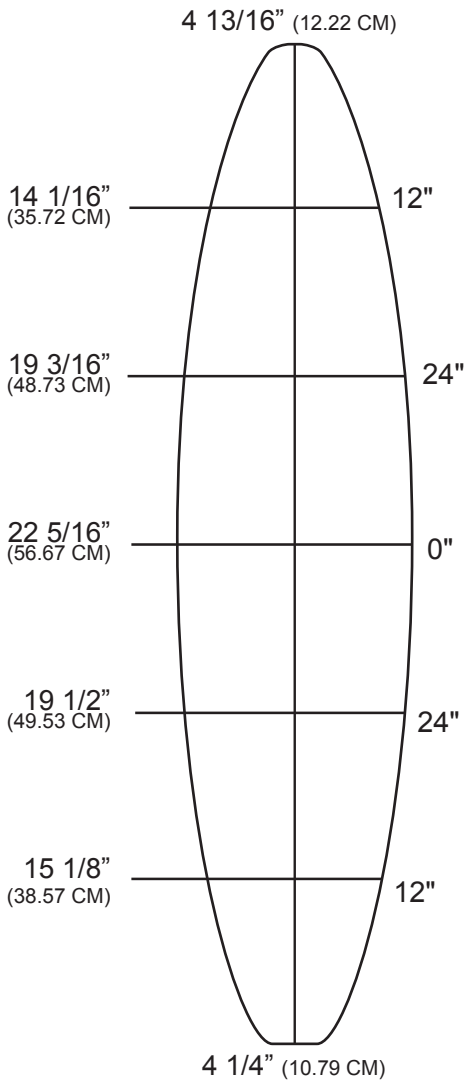

BOTTOM LENGTH: 7' 10 1/4"
(240.03 CM)

TIP TO TIP LENGTH: 7' 9 1/2"
(237.49 CM)

MAX WIDTH: 22 5/16" (56.67 CM)

THE 710DG IS A CONTINUATION OF OUR VERY POPULAR "DG" SERIES OF MACHINE BLANKS. MUCH LIKE THE OTHER BLANKS IN THE SERIES, THE 710DG CARRIES A FULLER DECK PROFILE ALL THE WAY TO THE RAIL. THE NATURAL ROCKER IS WELL PROPORTIONED FOR THE SIZE AND SHOULD TAKE ADJUSTMENTS WELL.

VOLUME: 69.9 L

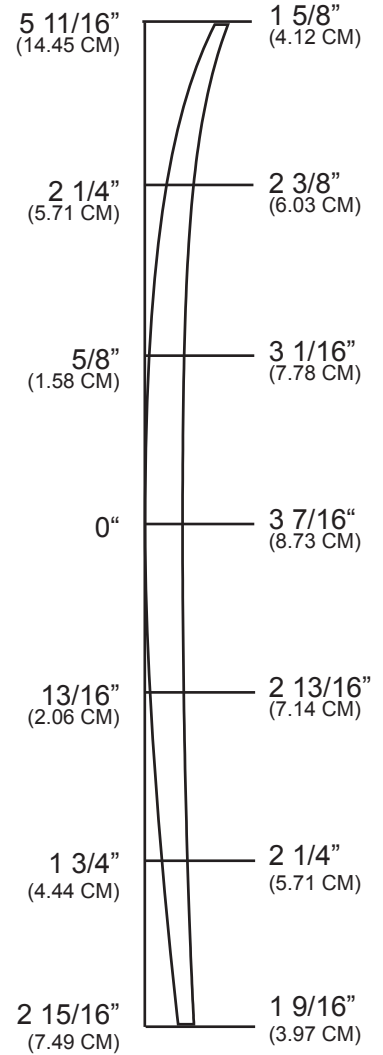

CENTER DECK SCALE CROSSSECTION

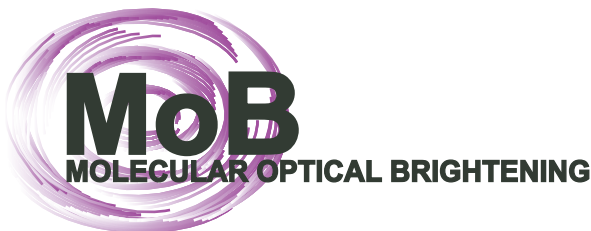

MILLENNIUM
FOAM  BUILD ON QUALITY

ORDER@MILLENNIUMFOAM.COM
310.323.5386

7'11"CB

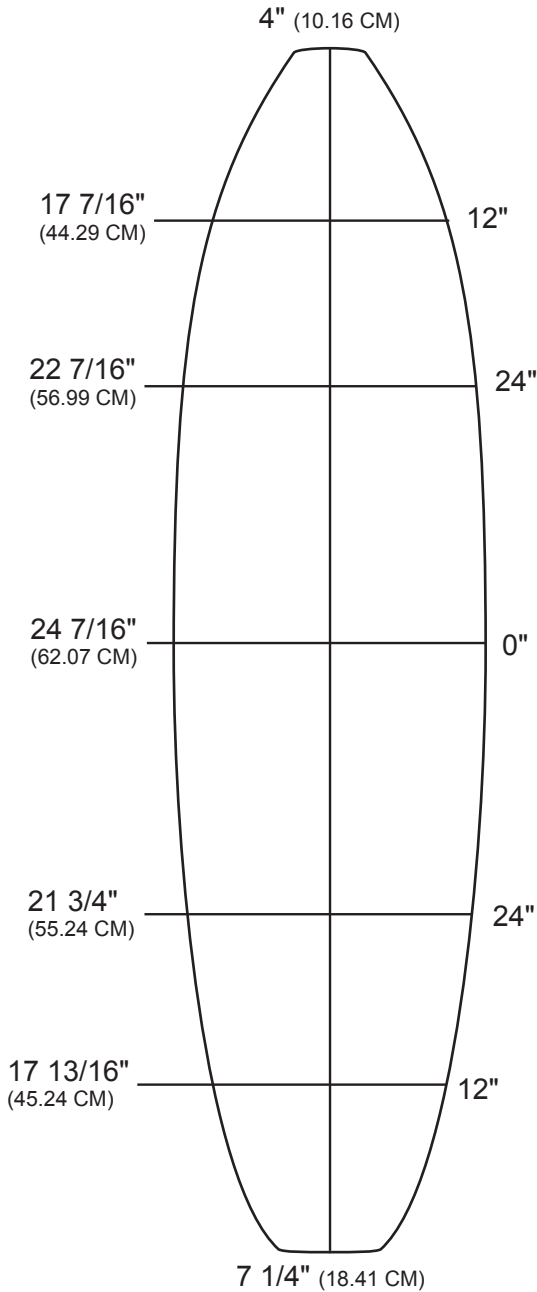

BOTTOM LENGTH: 7 11 5/16" (242.1 CM)

TIP TO TIP DECK: 7' 10 7/16" (239.9 CM)

MAX WIDTH: 24 7/16" (62.07 CM)

MAX THICKNESS: 3 5/16" (8.41 CM)

SHAPED BY: CHRIS BORST
MARCH 2006

BLANK DESIGNED FOR
MACHINE CUTTING. WITH
EXTRA THICKNESS. BLANK IS
SUITED WELL FOR BIG EGGS,
HYBRIDS, ETC.

VOLUME: 77.6L

WIRE FRAME BLANK MAP NOT TO SCALE

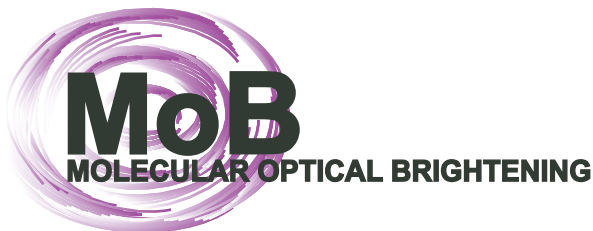
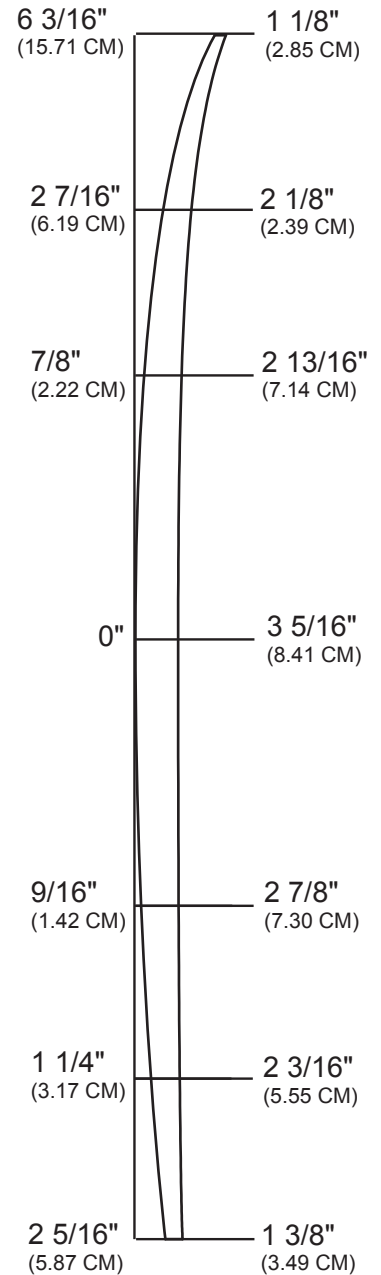

MILLENNIUM
FOAM  BUILD ON QUALITY

ORDER@MILLENNIUMFOAM.COM
310.323.5386

8'4"CB

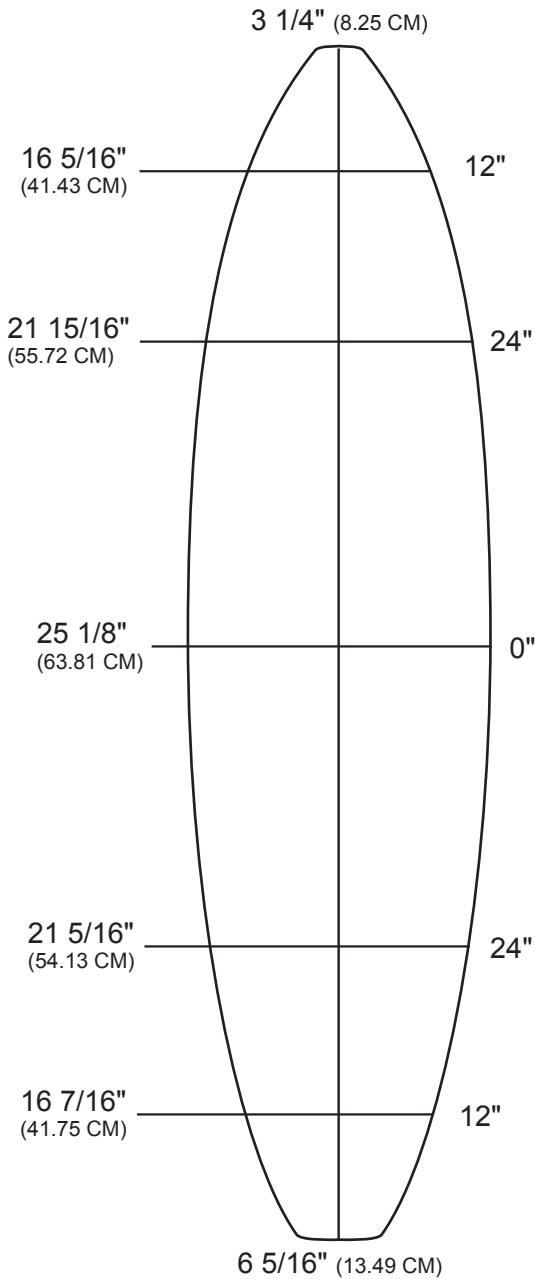

BOTTOM LENGTH: 8' 4 1/2"
(255.27 CM)

TIP TO TIP DECK: 8' 4" (254.0 CM)

MAX WIDTH: 25 1/8" (63.81 CM)

MAX THICKNESS: 3 5/16"
(8.41 CM)

SHAPED BY: CHRIS BORST
MARCH 2006

BLANK DESIGNED FOR
MACHINE CUTTING. BUILT
WITH EXTRA THICKNESS, AND
A FLATTER DECK. USED FOR
EGGS, HYBRIDS, MID SIZED
BOARDS...ETC.

VOLUME: 80.4L

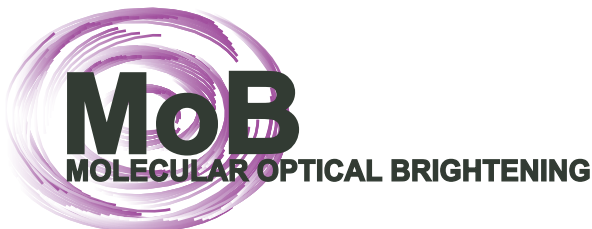
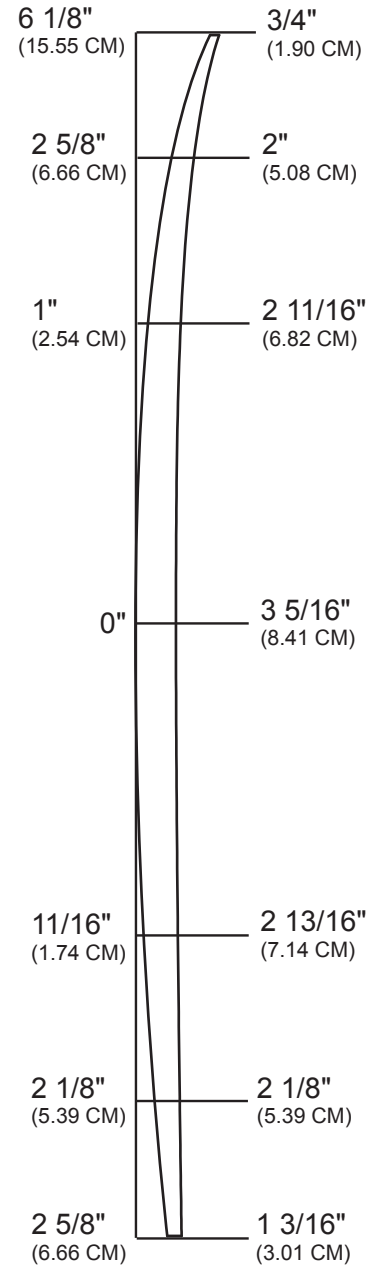

MILLENNIUM
FOAM  BUILD ON QUALITY

ORDER@MILLENNIUMFOAM.COM
310.323.5386

8'5"HS

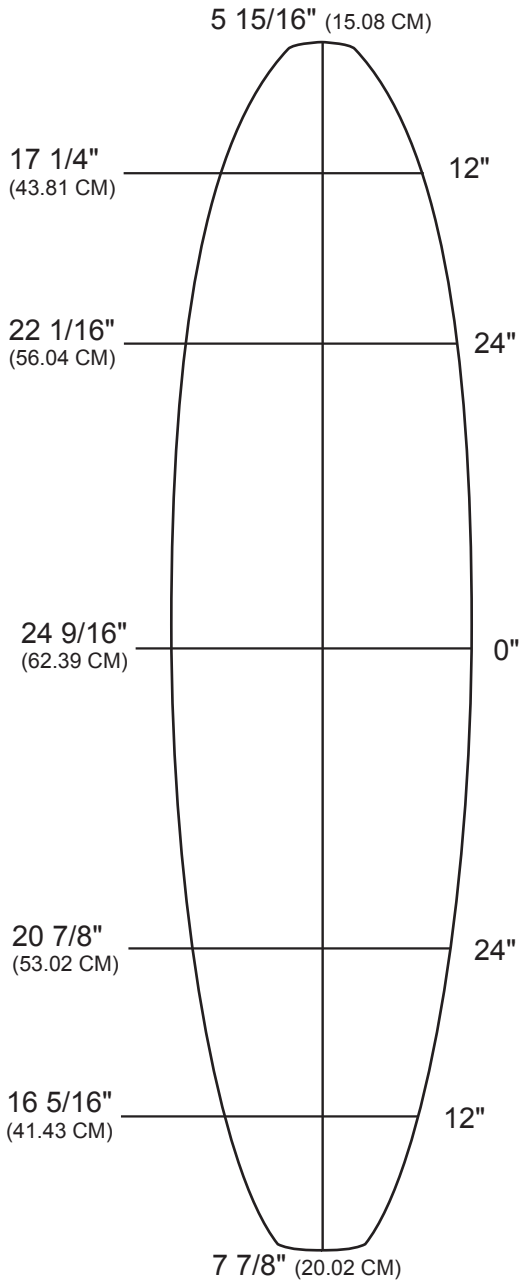

BOTTOM LENGTH: 8' 5 3/8"
(257.51 CM)

TIP TO TIP DECK: 8' 3" (251.46 CM)

MAX WIDTH: 24 9/16" (62.39 CM)

MAX THICKNESS: 4" (10.16 CM)

BLANK DESIGNED FOR MACHINE CUTTING. BUILT WITH EXTRA THICKNESS, AND A FLATTER DECK. USED FOR EGGS, HYBRIDS, MID SIZED BOARDS...ETC. THICKER THEN THE 8'4"CB

VOLUME: 89.91L

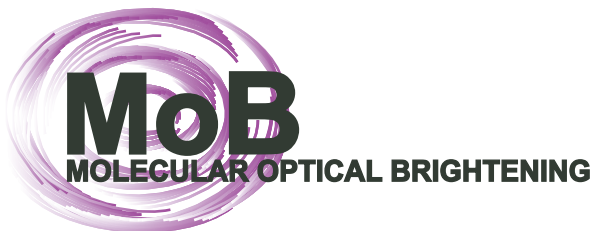
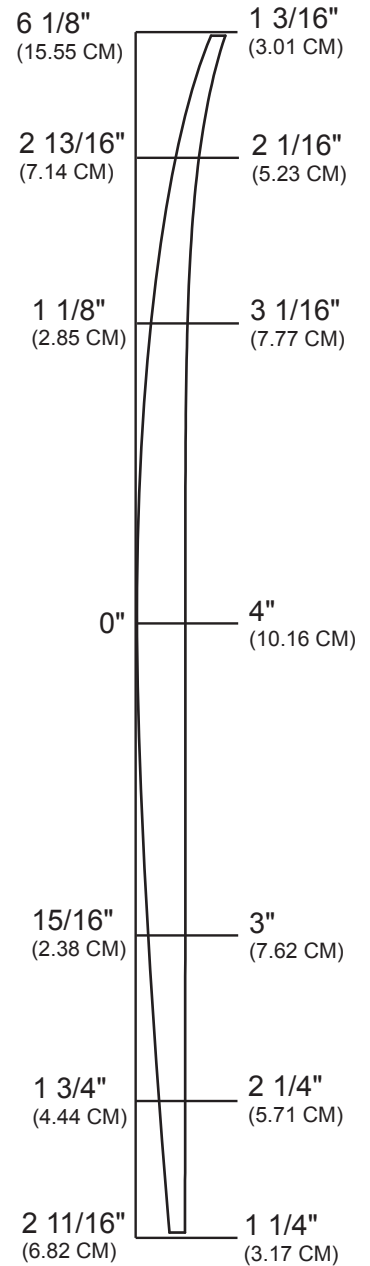

MILLENNIUM
FOAM  **BUILD ON QUALITY**

ORDER@MILLENNIUMFOAM.COM
310.323.5386

8'6" JC

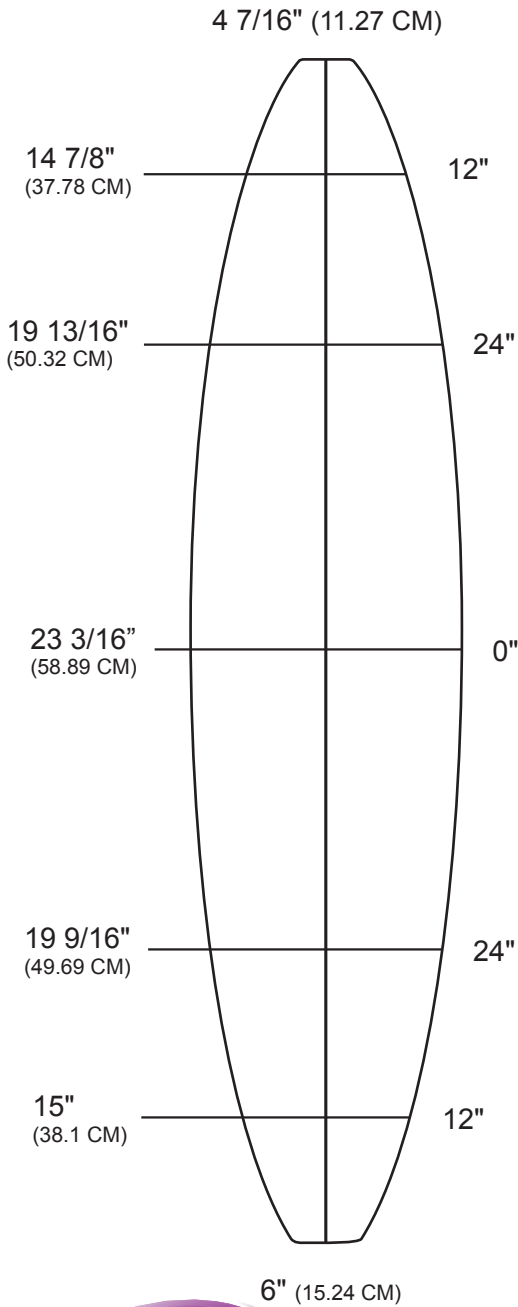

BOTTOM LENGTH: 8' 6"
(259.08 CM)

TIP TO TIP DECK: 8' 5" (256.69 CM)

MAX WIDTH: 23 3/16" (58.89 CM)

MAX THICKNESS: 3 1/2" (8.89 CM)

SHAPED BY: JOHN CARPER
DECEMBER 2006

BLANK IS DESIGNED FOR SUB
8'5" GUNS IN MIND. THE
CENTER THICKNESS IS
GENEROUS. VOLUME IS
CARRIED TO THE RAILS

VOLUME: 83.4L

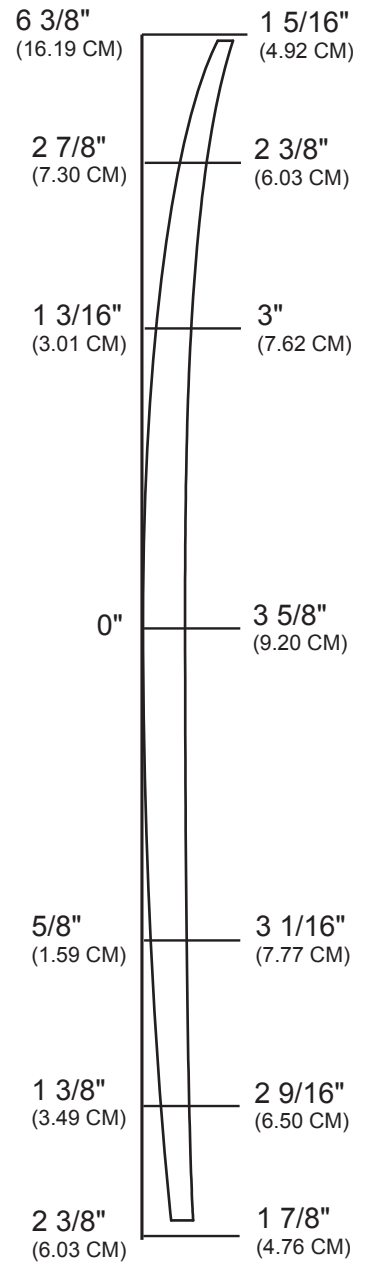

MILLENNIUM
FOAM  BUILD ON QUALITY

ORDER@MILLENNIUMFOAM.COM
310.323.5386

8'10"M

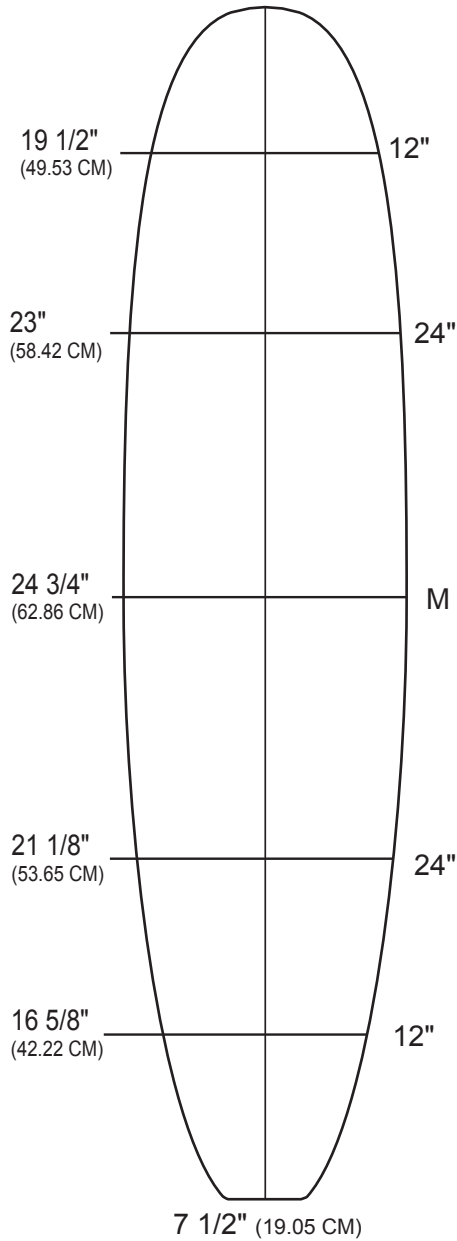

BOTTOM LENGTH: 8' 11"
(271.78 CM)

TIP TO TIP DECK: 8' 10"
(269.39 CM)

MAX WIDTH: 24 3/4" (62.86 CM)

MAX THICKNESS: 3 5/16"
(8.41 CM)

ROCKER: NATURAL
ALSO AVAILABLE WITH A
"CLASSIC" ROCKER PROFILE

SHAPED BY: BOB MITSVEN
SEPTEMBER 2006

THIS BLANK IS IDEAL FOR MINI
LONGBOARDS. I CARRIED
MORE VOLUME TO THE RAIL,
AND LEFT SOME THICKNESS
IN THE TAIL AND NOSE. THIS
MAINTAINS A CONSISTENT
THICKNESS FLOW, NOSE TO
TAIL.

VOLUME: 92.9L

WIRE FRAME BLANK MAP NOT TO SCALE

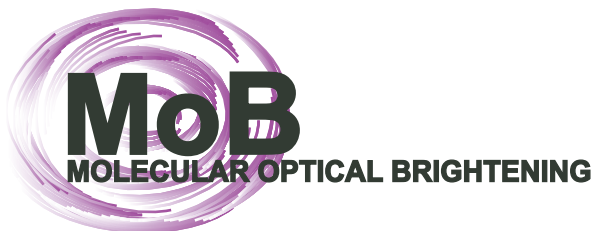
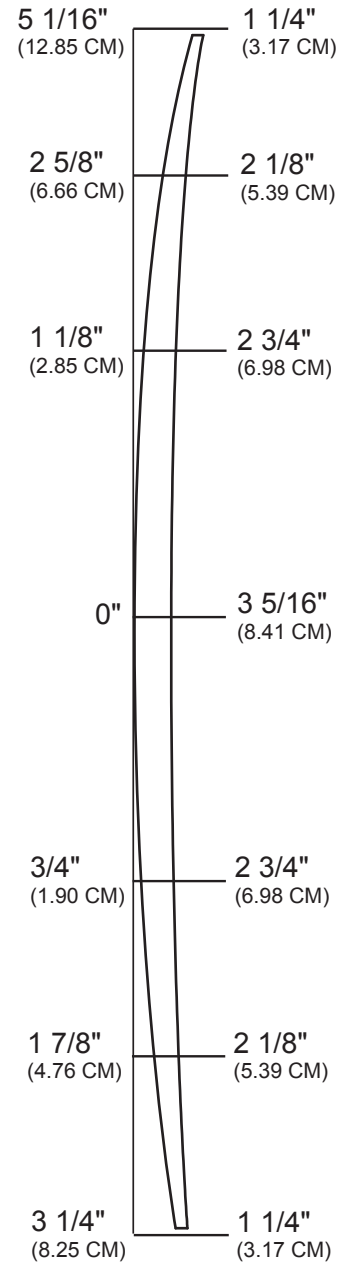

MILLENNIUM
FOAM  **BUILD ON QUALITY**

ORDER@MILLENNIUMFOAM.COM
310.323.5386

9'3"G

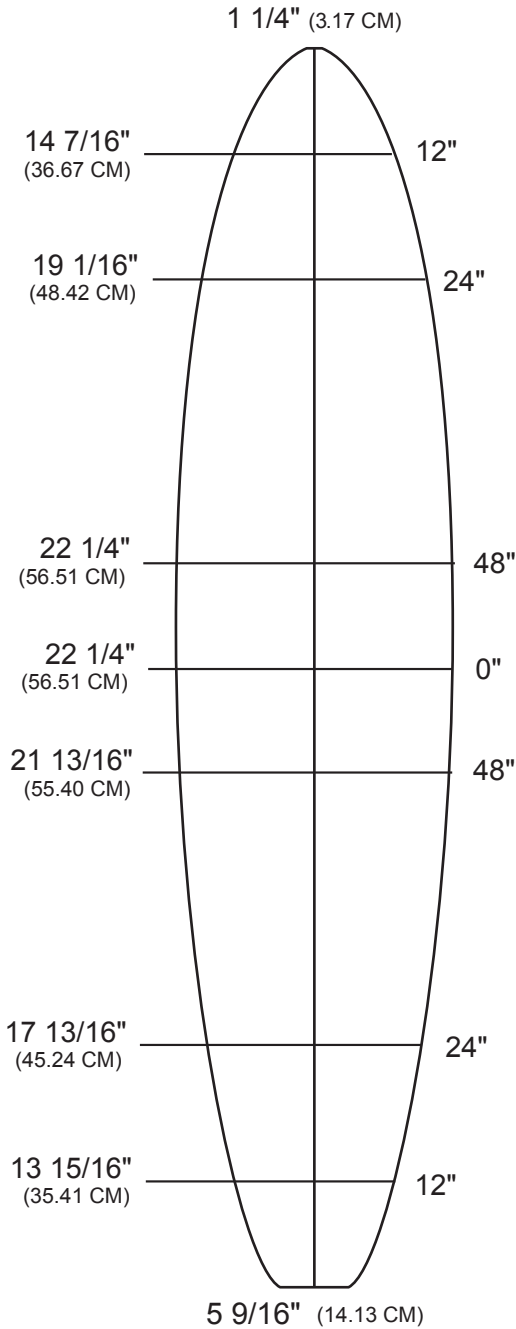

BOTTOM LENGTH: 9' 4 3/4"
(316.23 CM)

TIP TO TIP DECK: 9' 3 13/16"
(314.96 CM)

MAX WIDTH: 22 5/16" (61.43 CM)

MAX THICKNESS: 3 15/16"
(10.47 CM)

THIS REPRESENTS THE FIRST BIG GUN IN OUR "G" SERIES. DESIGNED WITH THE CURRENT TREND IN GUN DESIGN, THE THICKNESS AND WIDTH ARE BOTH CARRIED BEYOND THE MID POINT TOWARDS THE NOSE. THIS MAKES THESE BLANKS IDEALLY SUITED FOR EXTRA THICKNESS AND WIDTH UNDER THE CHEST FOR PADDLING. THE "G" SERIES HAS BEEN DESIGNED WITH BOTH HANDSHAPING AND MACHINE CUTTING IN MIND. THIS BLANK CARRIES 3 1/8" OF THICKNESS TO THE RAIL CROWN AT THE CENTER OF THE BLANK.

VOLUME: 95.7 L

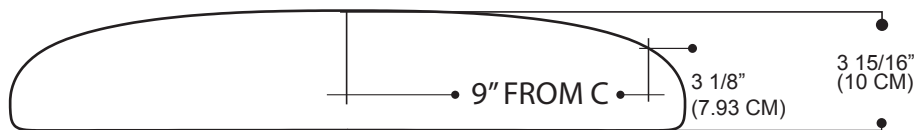
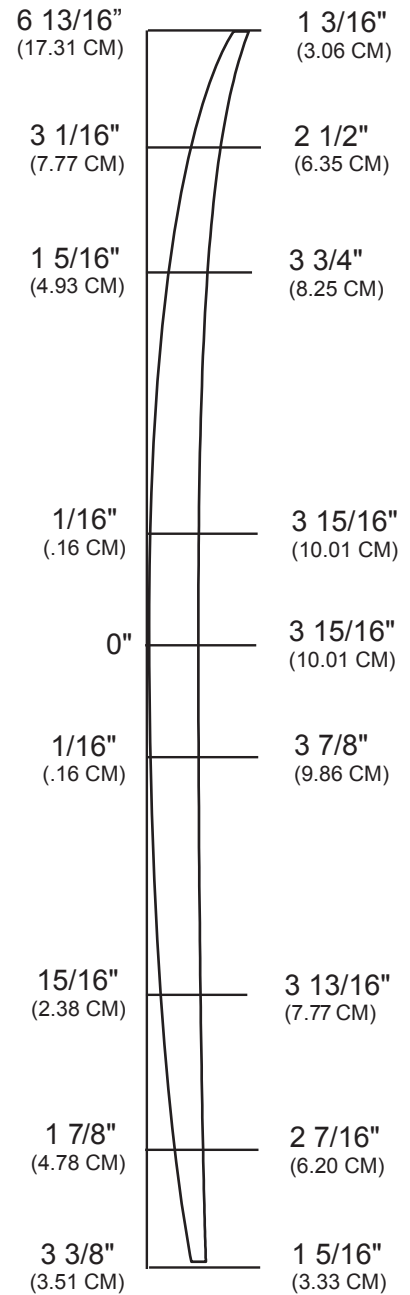

CENTER DECK VIEW CROSSSECTION

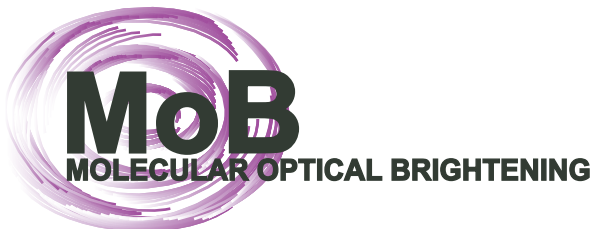

MILLENNIUM
FOAM BUILD ON QUALITY

ORDER@MILLENNIUMFOAM.COM
310.323.5386

9'4" M

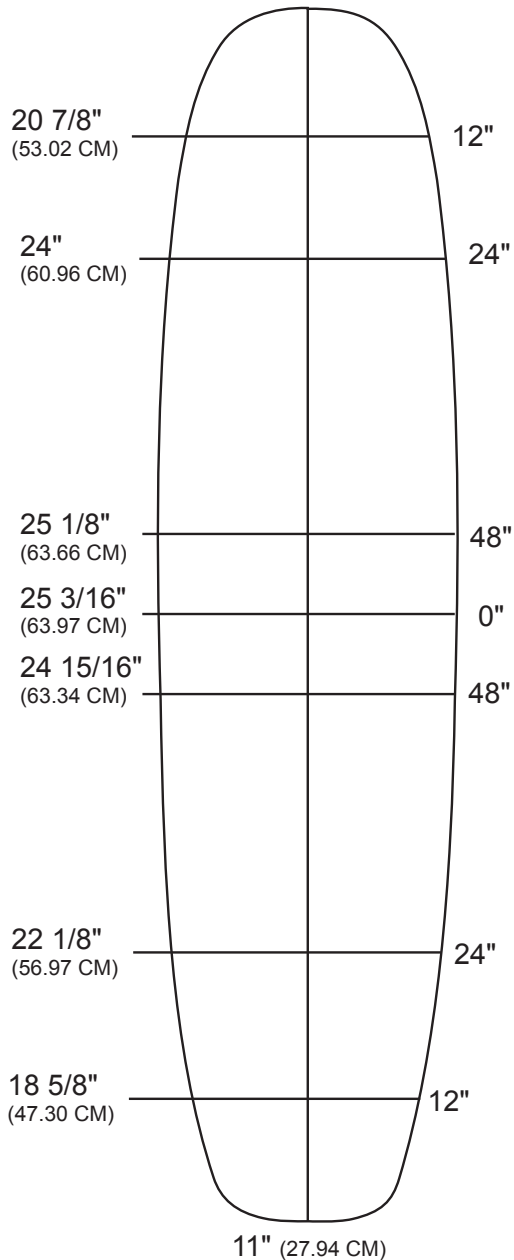

BOTTOM LENGTH: 9' 4 1/2"
(285.11 CM)

TIP TO TIP DECK: 9' 3" (281.94 CM)

MAX WIDTH: 25 3/16" (63.97 CM)

MAX THICKNESS: 3 5/16"
(8.41 CM)

SHAPED BY:
BOB MITSVEN, NOVEMBER
2008

CLOSER TOLERANCE
LONGBOARD BLANK. GOOD
FOIL FOR 9'0-9'3
LONGBOARDS. 11" TAIL BLOCK
PROVIDES MAXIMUM TAIL
WIDTH VERSITILITY.

VOLUME: 102.2L

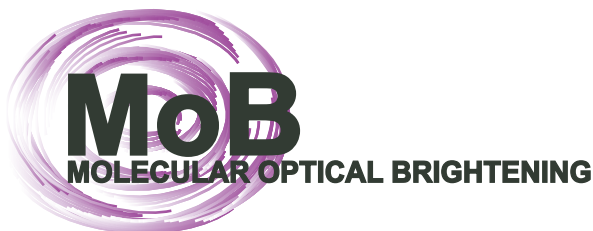
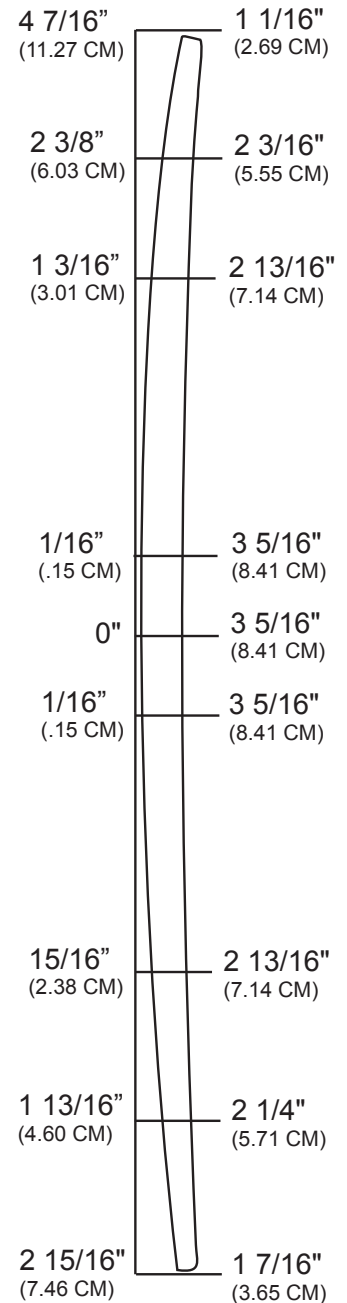

MILLENNIUM
FOAM  **BUILD ON QUALITY**

ORDER@MILLENNIUMFOAM.COM
310.323.5386

9'5"

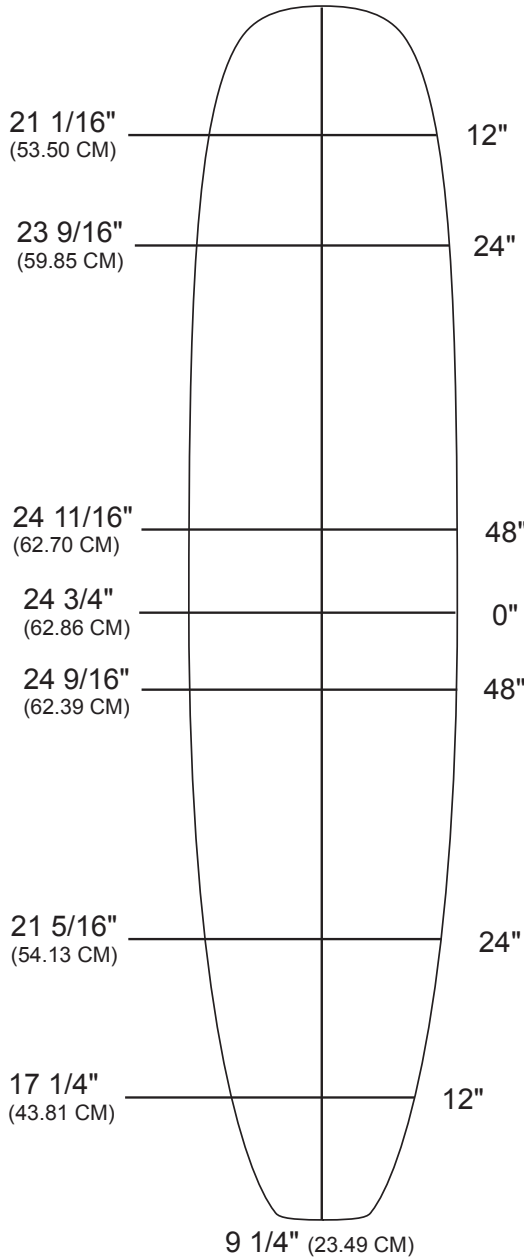

BOTTOM LENGTH: 9' 4 5/16"
(285.27 CM)

TIP TO TIP DECK: 9' 3 3/4"
(283.84 CM)

MAX WIDTH: 24 3/4" (62.86 CM)

MAX THICKNESS: 3 1/2" (8.89 CM)

STANDARD LONGBOARD
BLANK.GENEROUS VOLUME
MAKES THIS BLANK IDEAL
FOR MACHINE CUTTING.
IDEALY SUITED THICKER TYPE
LONGBOARDS

VOLUME:105.6L

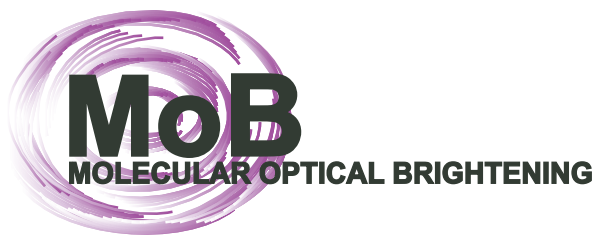
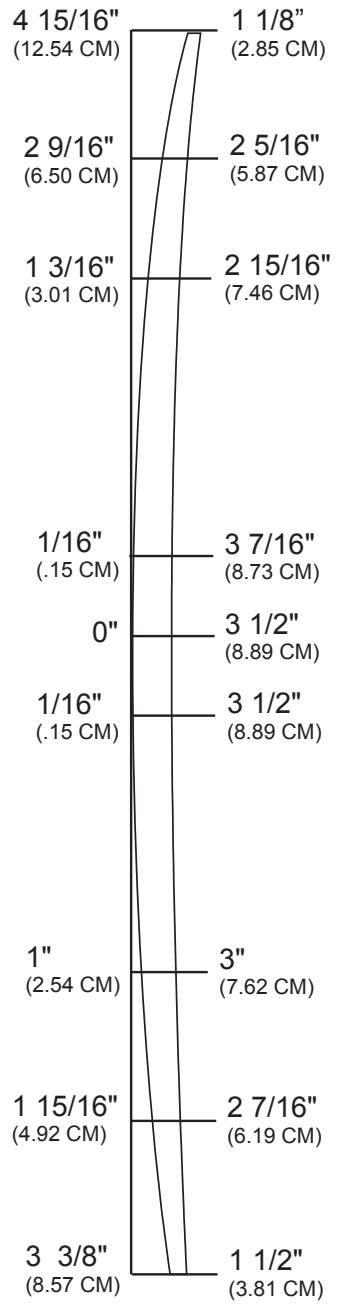

MILLENNIUM
FOAM  BUILD ON QUALITY

ORDER@MILLENNIUMFOAM.COM
310.323.5386

9'7"G

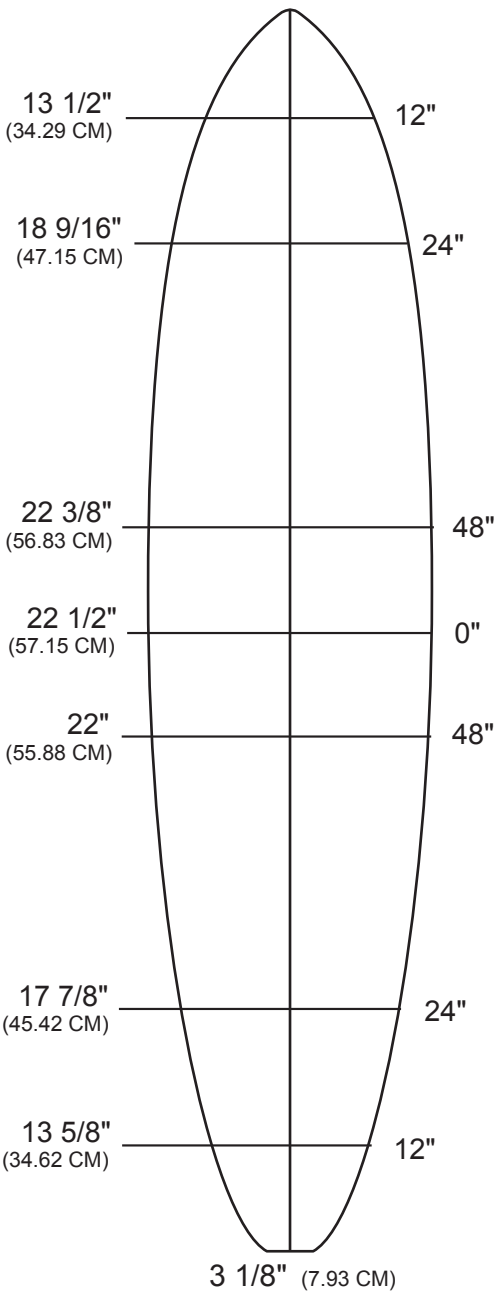

BOTTOM LENGTH: 9' 7 1/8"
(292.43 CM)

TIP TO TIP DECK: 9' 6 3/16"
(290.04 CM)

MAX WIDTH: 22 1/2" (57.15 CM)

MAX THICKNESS: 4 5/16"
(10.69 CM)

THIS IS THE SECOND BIG GUN IN OUR "G" SERIES. DESIGNED WITH THE CURRENT TREND IN GUN DESIGN, THE THICKNESS AND WIDTH ARE BOTH CARRIED BEYOND THE MID-POINT TOWARDS THE NOSE. THIS MAKES THESE BLANKS IDEALLY SUITED FOR EXTRA THICKNESS AND WIDTH UNDER THE CHEST FOR PADDLING. THIS BLANK CARRIES 3 7/16" OF THICKNESS TO THE RAIL CROWN AT THE CENTER OF THE BLANK.

VOLUME: 106.6 L

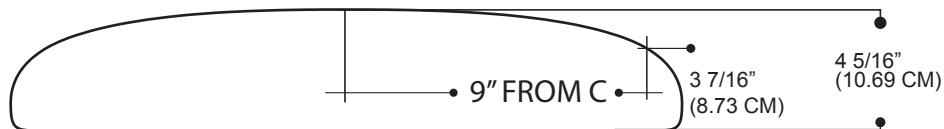
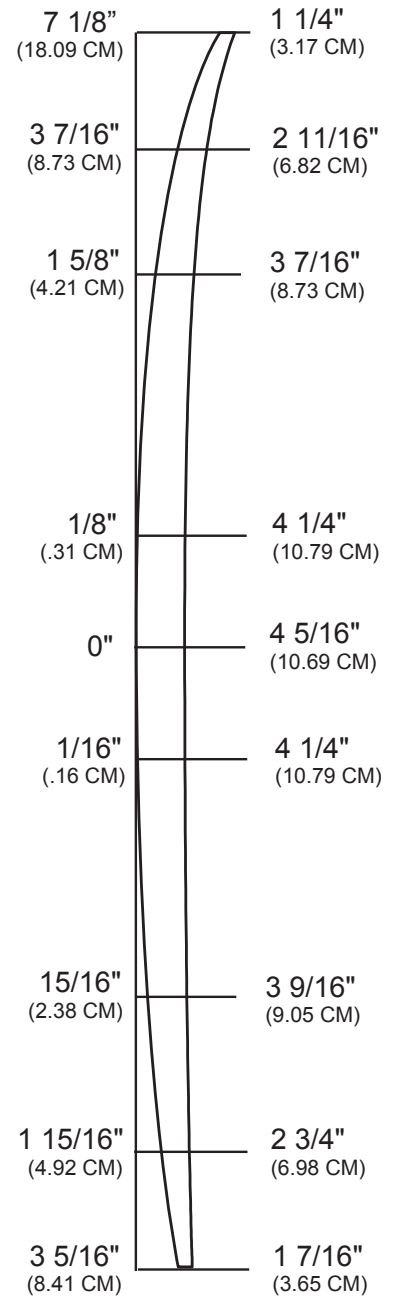

CENTER DECK VIEW CROSSECTION

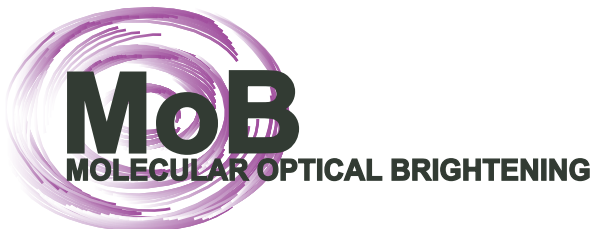

MILLENNIUM
FOAM BUILD ON QUALITY

ORDER@MILLENNIUMFOAM.COM
310.323.5386

9'8"CB

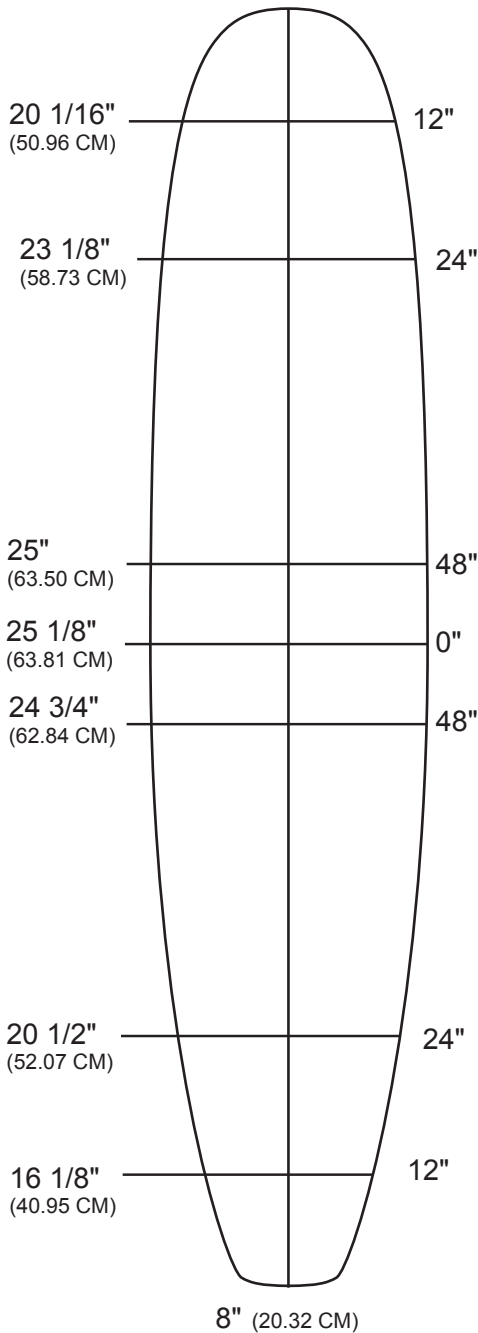

BOTTOM LENGTH: 9' 8 1/4"
(300.35 CM)

TIP TO TIP DECK: 9' 7 3/4"
(292.10 CM)

MAX WIDTH: 25 1/8" (63.81 CM)

MAX THICKNESS: 3 11/16"
(9.36 CM)

SHAPED BY: CHRIS BORST
MARCH 2006

THIS BLANK WAS DESIGNED
FOR MACHINE CUTTING.
IDEAL FOR COMP TYPE
LONGBOARDS.

VOLUME: 108.4L

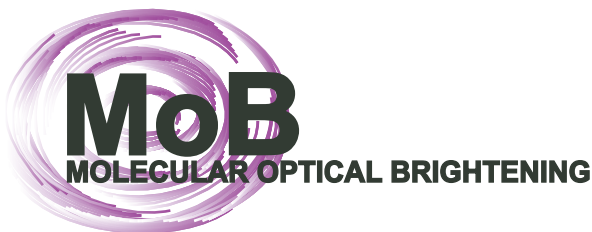
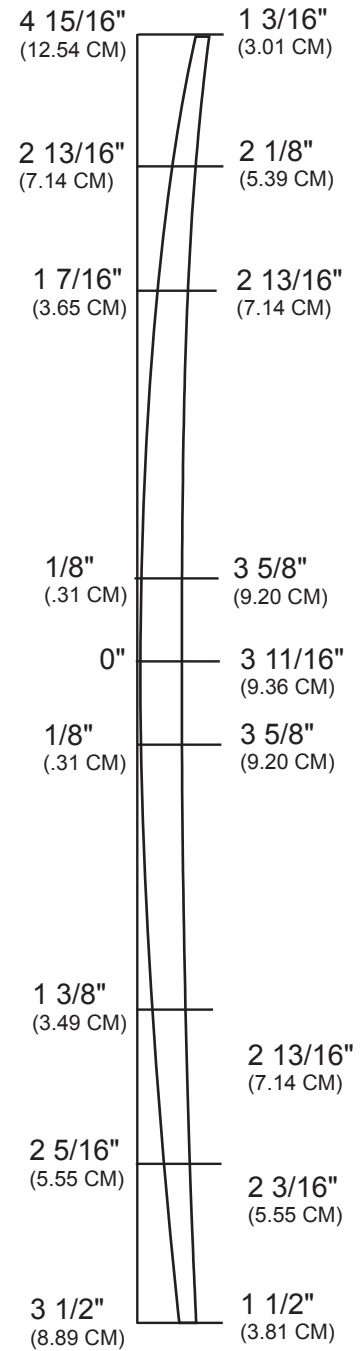

MILLENNIUM
FOAM  BUILD ON QUALITY

ORDER@MILLENNIUMFOAM.COM
310.323.5386

9'9"Y

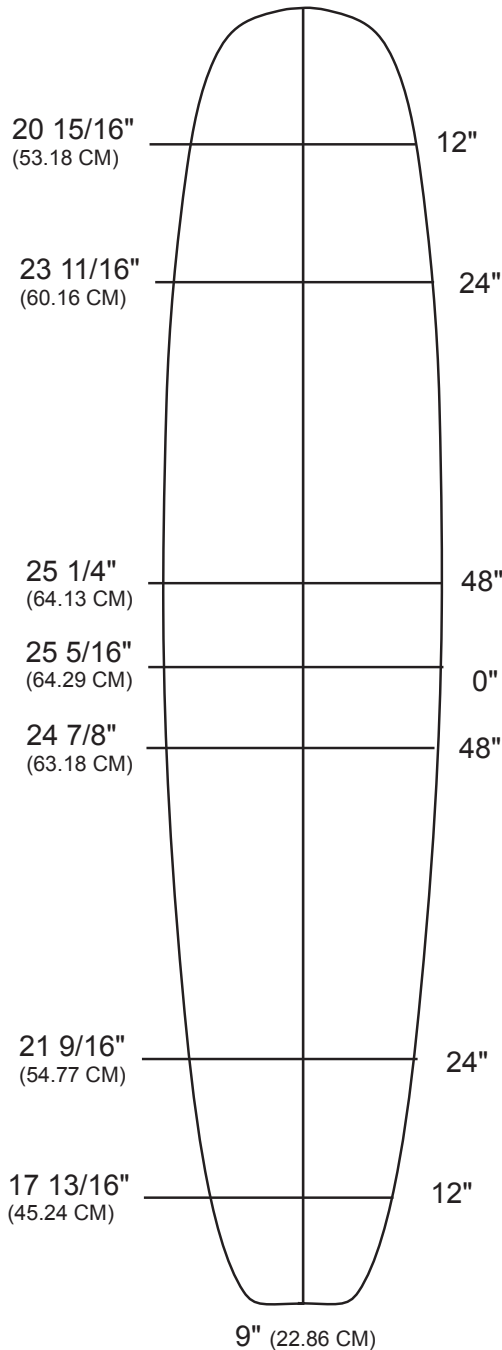

BOTTOM LENGTH: 9' 9 1/4" (297.81 CM)

TIP TO TIP DECK: 9' 8 3/4" (294.64 CM)

MAX WIDTH: 25 5/16" (64.79 CM)

MAX THICKNESS: 3 1/2" (8.89 CM)

SHAPED BY: RENNY YATER
SEPTEMBER 2006

COMMENTS: A NEWER VERSION OF THE ORIGINAL 9'9"Y. WITH PLENTY OF WIDTH FRONT AND BACK, IT IS DESIGNED FOR A MORE CLASSIC LONGBOARD.

VOLUME: 114.0L

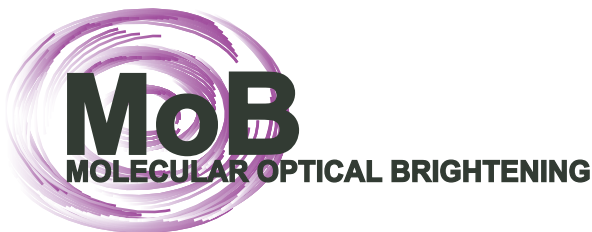
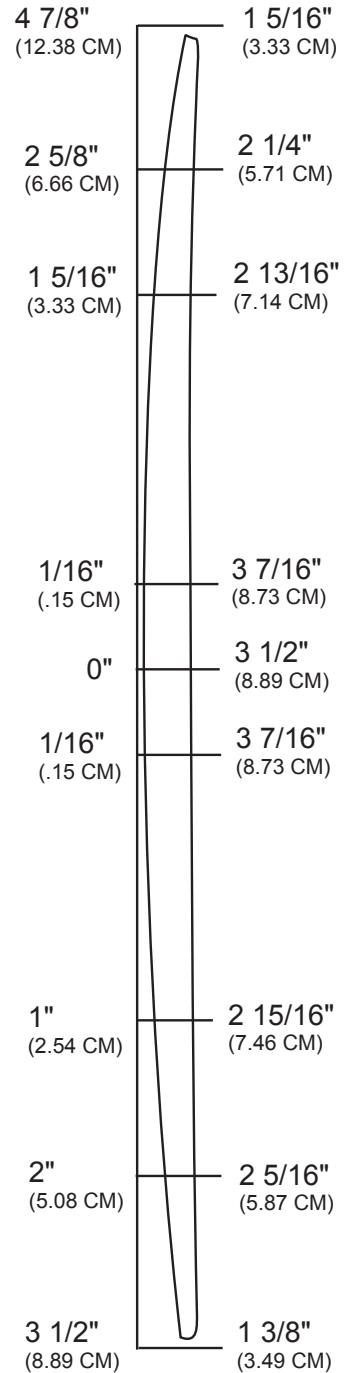

MILLENNIUM
FOAM BUILD ON QUALITY

ORDER@MILLENNIUMFOAM.COM
310.323.5386

10'3"CB

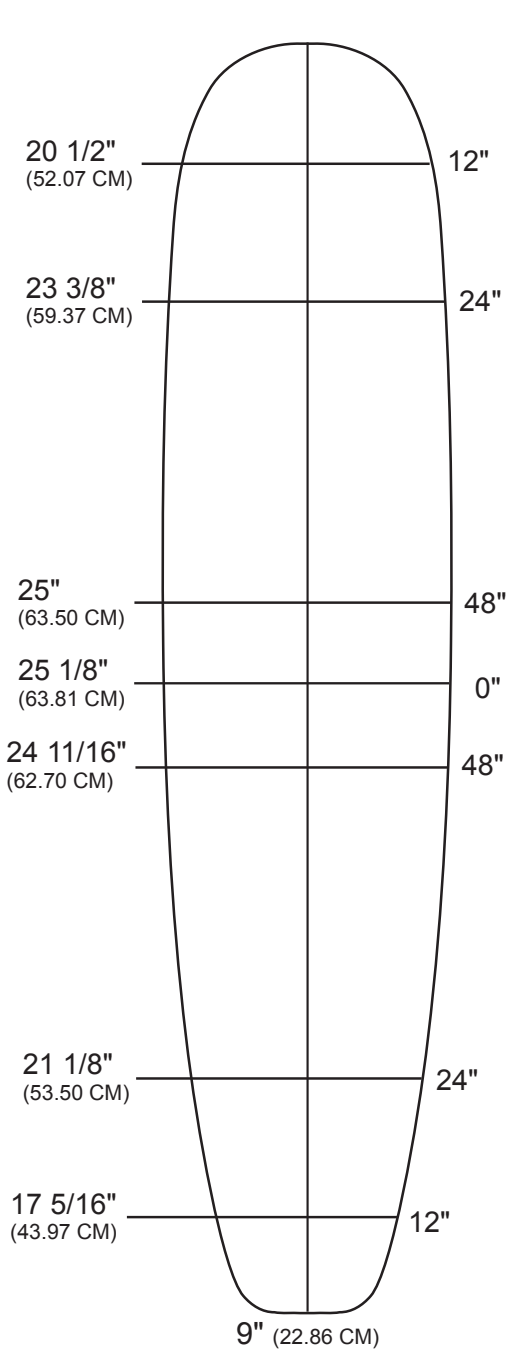

BOTTOM LENGTH: 10' 2 1/2"
(311.55 CM)

TIP TO TIP DECK: 10' 2"
(309.88 CM)

MAX WIDTH: 25 1/8" (63.85 CM)

MAX THICKNESS: 3 7/8" (9.84 CM)

SHAPED BY: CHRIS BORST
APRIL 2006

THIS BLANK IS DESIGNED FOR
THE MACHINE. FULL
THICKNESS ALLOWS FOR MAX
VERSATILITY

VOLUME: 125.8L

WIRE FRAME BLANK MAP NOT TO SCALE

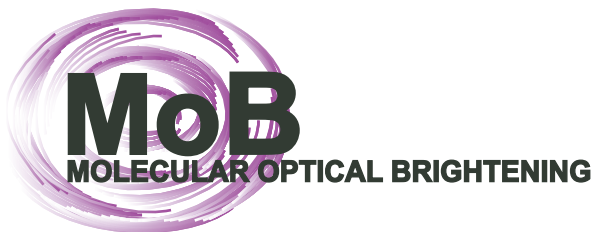
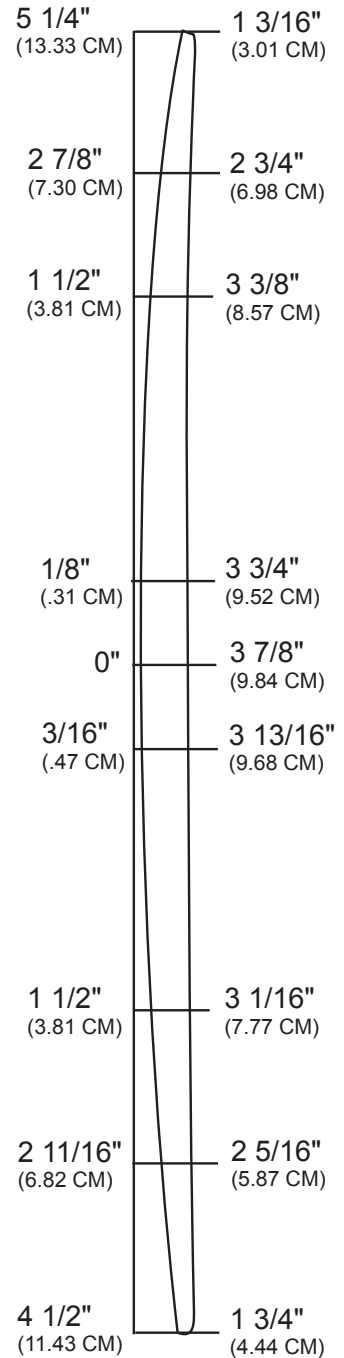

MILLENNIUM
FOAM BUILD ON QUALITY

ORDER@MILLENNIUMFOAM.COM
310.323.5386

10'3"G

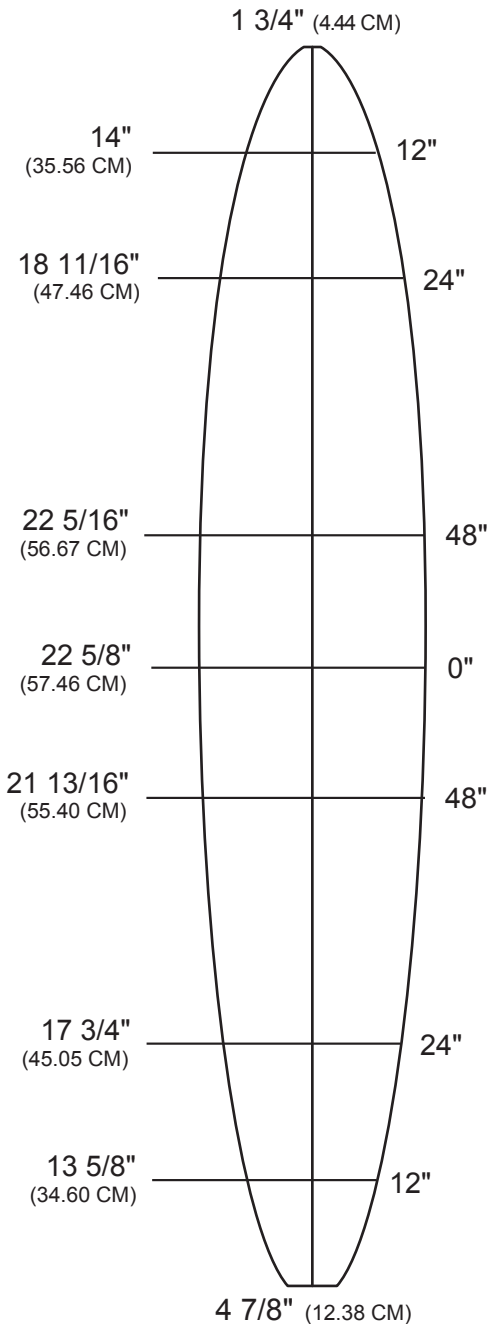

BOTTOM LENGTH: 10' 4 5/8"
(316.56 CM)

TIP TO TIP DECK: 10' 3 5/8"
(314.02 CM)

MAX WIDTH: 22 5/8" (57.46 CM)

MAX THICKNESS: 4 3/8"
(11.11 CM)

THIS IS THE THIRD BIG GUN IN OUR "G" SERIES. DESIGNED WITH THE CURRENT TREND IN GUN DESIGN IN MIND, THE THICKNESS AND WIDTH ARE BOTH CARRIED BEYOND THE MID POINT TOWARDS THE NOSE. THIS MAKES THESE BLANKS IDEALLY SUITED FOR EXTRA THICKNESS AND WIDTH UNDER THE CHEST FOR PADDLING. THIS BLANK CARRIES 3 1/2" OF THICKNESS TO THE RAIL CROWN AT THE CENTER OF THE BLANK.

VOLUME: 119.2 L

WIRE FRAME BLANK MAP NOT TO SCALE

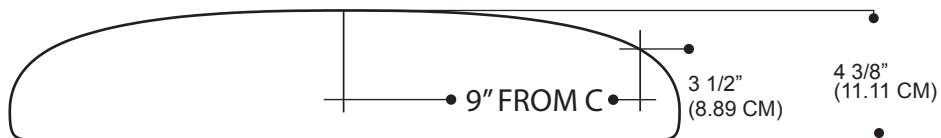
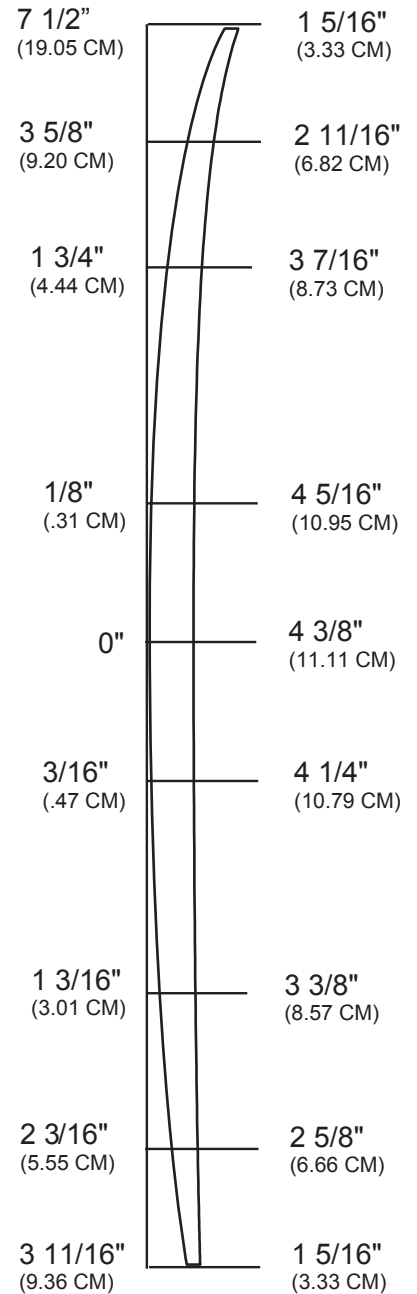

CENTER DECK VIEW CROSSECTION

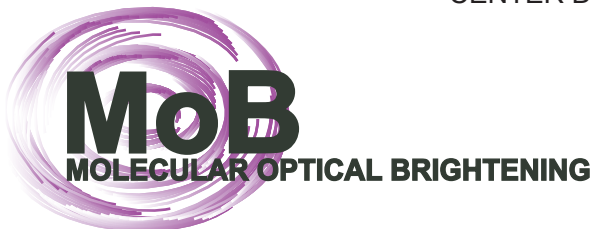

MILLENNIUM
FOAM BUILD ON QUALITY

ORDER@MILLENNIUMFOAM.COM
310.323.5386

10'7"G

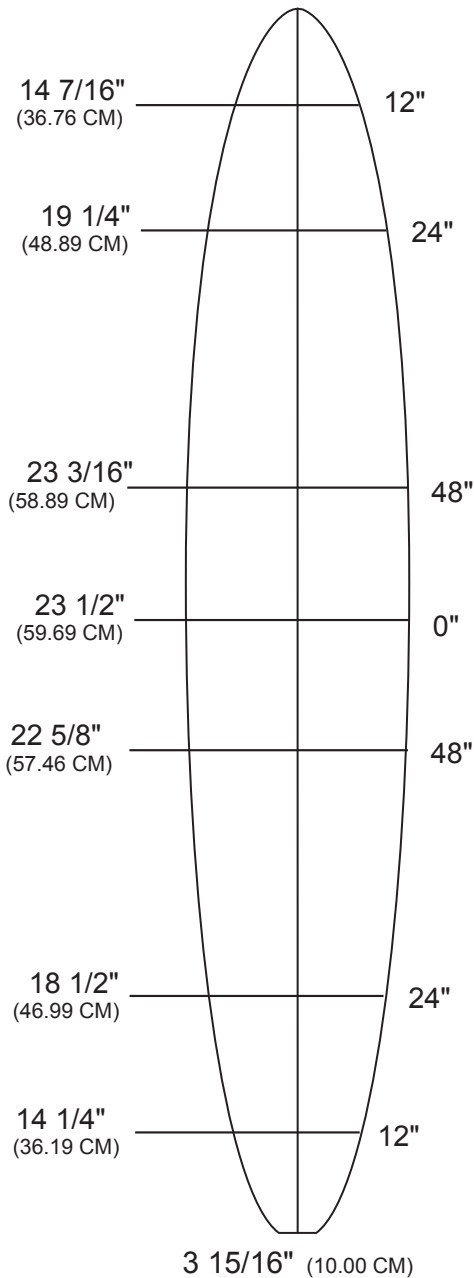

BOTTOM LENGTH: 10' 7 3/8"
(323.55 CM)

TIP TO TIP DECK: 10' 6 3/8"
(321.01 CM)

MAX WIDTH: 23 1/2" (59.69 CM)

MAX THICKNESS: 4 5/8"
(11.74 CM)

THIS IS THE FOURTH BIG GUN IN OUR "G" SERIES. DESIGNED WITH THE CURRENT TREND IN GUN DESIGN IN MIND, THE THICKNESS AND WIDTH ARE BOTH CARRIED BEYOND THE MID POINT TOWARDS THE NOSE. THIS MAKES THESE BLANKS IDEALLY SUITED FOR EXTRA THICKNESS AND WIDTH UNDER THE CHEST FOR PADDLING. THIS BLANK CARRIES 3 13/15" OF THICKNESS AT THE RAIL CROWN AT THE CENTER OF THE BLANK. THIS PROVIDES VERSATILE THICKNESS OUT AT THE RAIL

VOLUME: 134.6 L

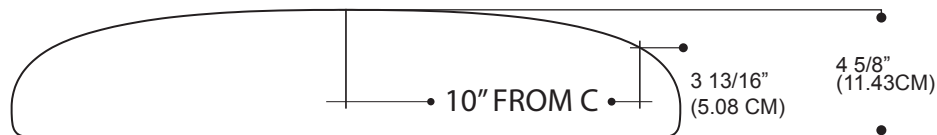
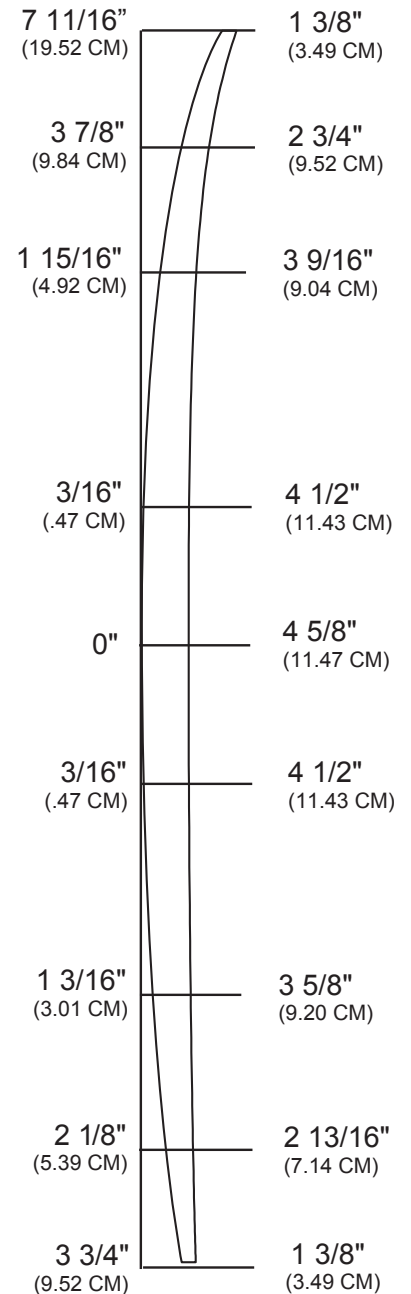

CENTER DECK VIEW CROSSECTION



MILLENNIUM
FOAM  **BUILD ON QUALITY**

ORDER@MILLENNIUMFOAM.COM
310.323.5386

11'1"CB

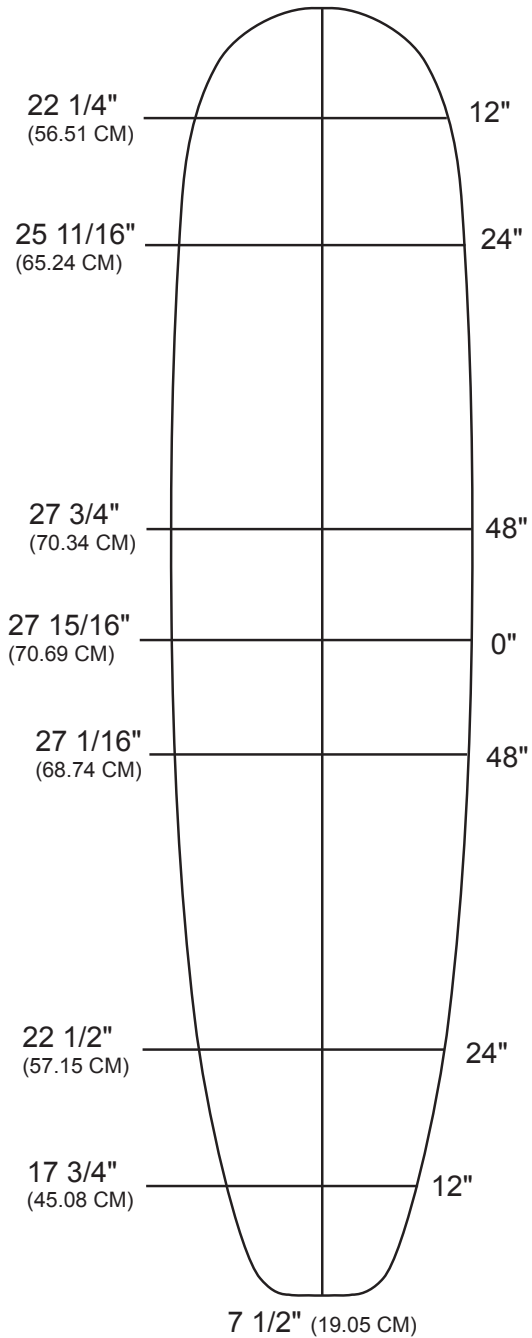

BOTTOM LENGTH: 11' 2"
(340.36 CM)

TIP TO TIP DECK: 11' 1"
(337.82 CM)

MAX WIDTH: 27 15/16"
(70.69 CM)

MAX THICKNESS: 4 11/16"
(11.90 CM)

SHAPED BY: CHRIS BORST

IDEAL FOR THICKER LONGBOARDS. FLAT DECK LETS THICKNESS CARRY TO THE RAILS. DESIGNED FOR THE MACHINE

VOLUME: 185.9L

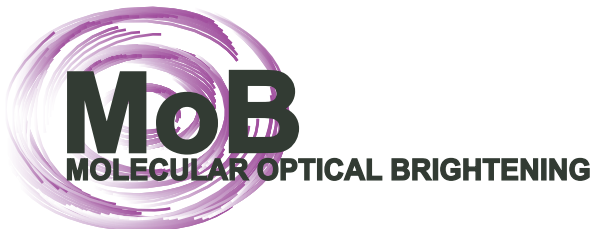
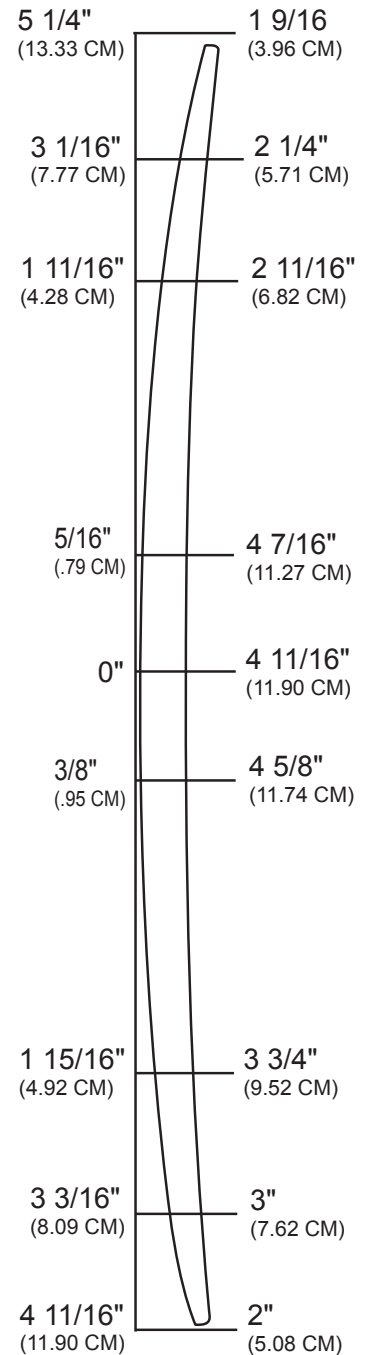

MILLENNIUM
FOAM  **BUILD ON QUALITY**

ORDER@MILLENNIUMFOAM.COM
310.323.5386